

THE PROFESSIONAL MAGAZINE FOR ELECTRONICS AND COMPUTER SERVICING

# ELECTRONIC<sup>TM</sup>

## Servicing & Technology

November 1998

Extending soldering tip life

Microwave oven servicing

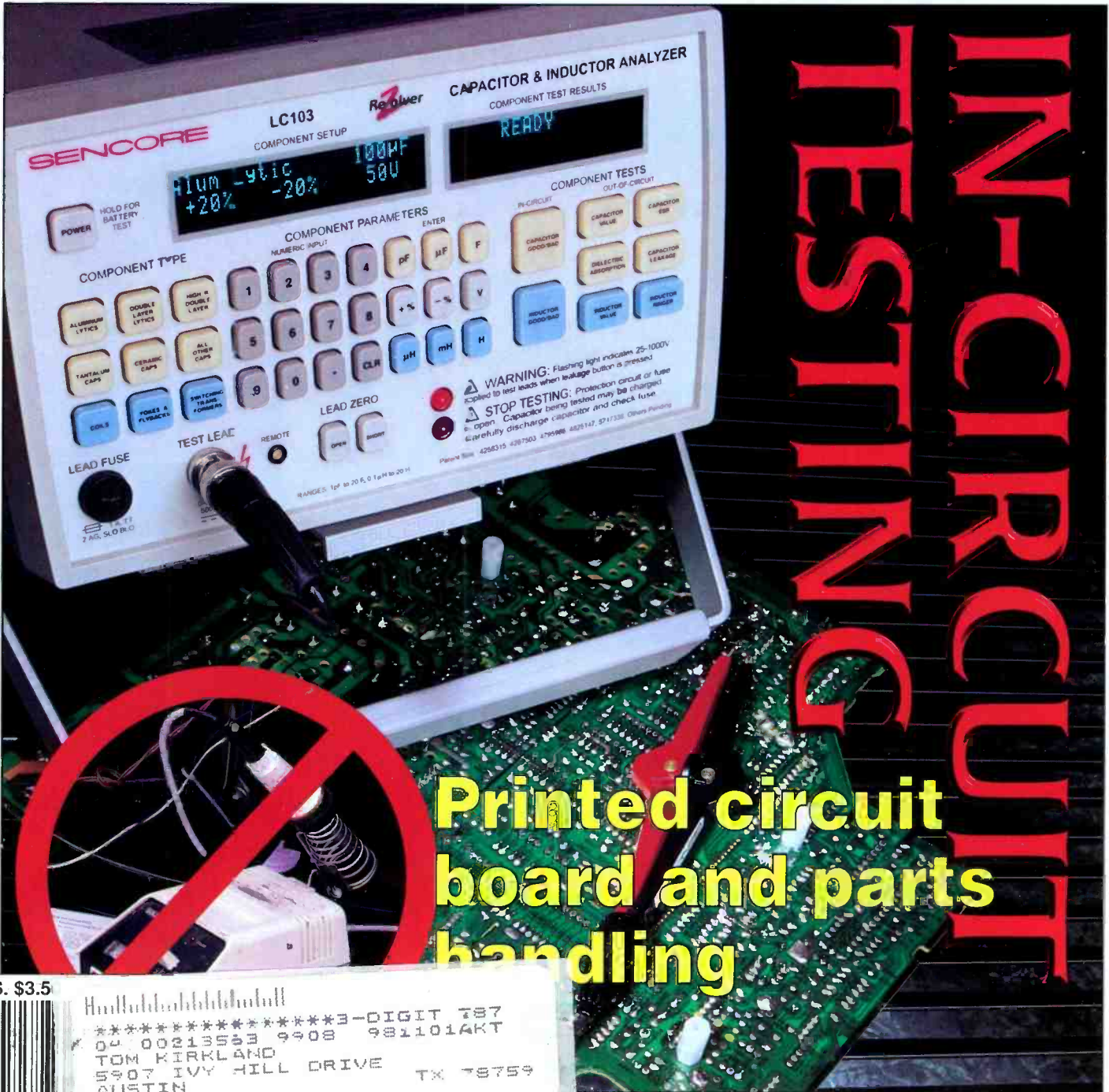

# IN-CIRCUIT TESTING

## Printed circuit board and parts handling

U.S. \$3.5



\*\*\*\*\*9-DIGIT 787  
 04 00213553 9908 981101AKT  
 TOM KIRKLAND  
 5907 IVY HILL DRIVE TX 78759  
 AUSTIN

7 2527

we deliver  
timely solutions,  
every day.

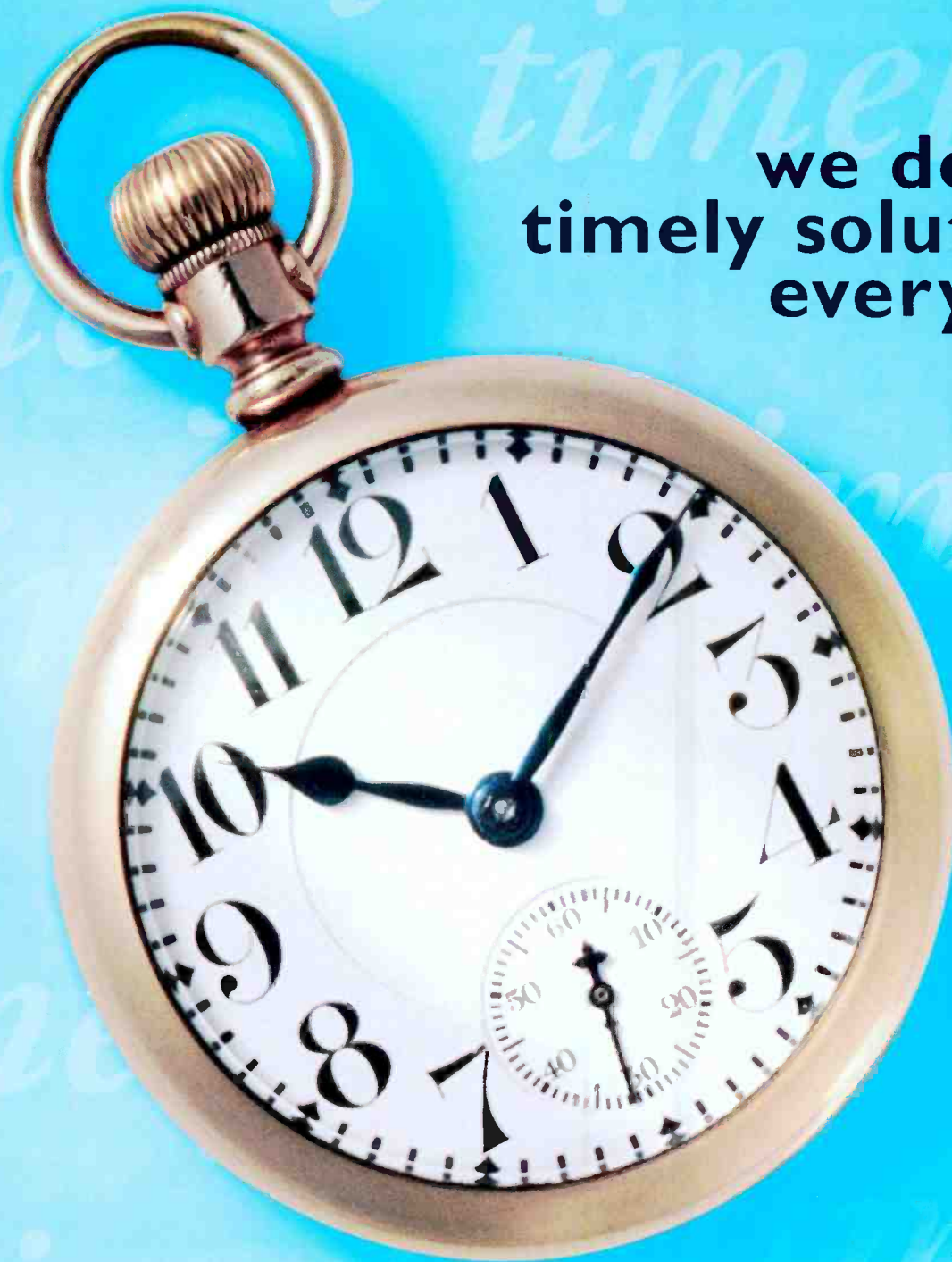

**Working harder for you.**

When you need help right away, call Philips Smart Parts. We're working hard to make sure your customers are completely satisfied. Call us today for all your parts, accessories, and service aids. **Call 800-851-8885.**



**PHILIPS**

Circle (120) on Reply Card

*Let's make things better.*

# ELECTRONIC

Servicing & Technology

Volume 18, No. 11 November, 1998

## Contents

### FEATURES

**6 Circuit board and parts handling**  
*by the ES&T Staff*

Miniaturization of components and ICs means that everything in today's consumer electronics products is more delicate, in some cases almost too small to be seen. Read this article for some tips on handling today's tightly packed PC boards and tiny components.

**8 Diagnostic software for the Y2K problem**  
*by the ES&T Staff*

Since the introduction of personal computers, programmers have saved memory storage space by using two digits to represent the year; for example, 98 instead of 1998. This is no problem until New Year's Day of the year 2000. However, a number of software companies have come up with what they claim is a solution. Read this article for a description of the problem.

**10 Extending soldering iron tip life**  
*by Edwin Oh and Doug Wilkerson*

Even under normal usage, the plating on all soldering iron tips will eventually fail. This article gives suggestions on keeping soldering iron tips in operation longer.

**15 Microwave oven repair basics**  
*by John Ross*

This article uses an example microwave oven to show how components function and to illustrate basic repair solutions.

**24 Switched mode power supplies**  
*by John Ross*

Troubleshooting problems related to switched mode power supplies can be tricky. Read this article for a primer on

how these circuits operate, and some advice on ferreting out problems in them.

**51 Startup-shutdown problems in Philips' A8 chassis**

*by Bob Rose*

Because of the design of modern TV sets, most, if not all, of them require startup and shutdown circuits. The author of this article has ascertained that in the Philips' A8 chassis, any of seven circuits can cause startup-shutdown problems. Read his words of wisdom to learn how to determine which one of them might be the cause of a particular problem.



page 6

### DEPARTMENTS

2 Editorial

4 News

14 Calendar

23 Test Your Electronics Knowledge

29 Profax

50 PhotoFact

56 What Do You Know About Electronics?

58 Products

60 Literature

62 Classified

63 Reader's Exchange

64 Advertisers' Index



page 10

### ON THE COVER

Printed circuit boards are the basic building blocks of modern consumer electronics products. When a technician is troubleshooting one of these products, he is invariably handling one of these boards and the components that are mounted on it. Proper handling of these assemblies and components actually involves touching and manipulating them as little as is necessary to get the job done. (Photo courtesy of Sencore)

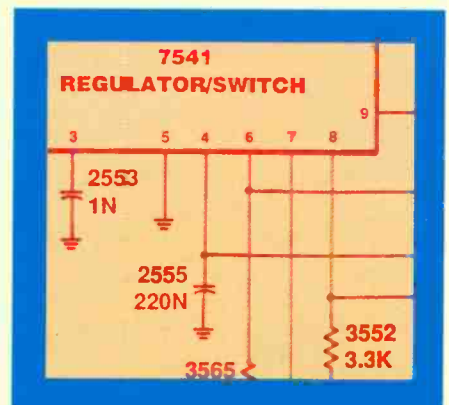

page 51

how you get

repair tips

YOUR

information...

Is this

in

stages

Circle #62 on  
Reply Card

— EDITORIAL —

## Diagnostic software

The idea of diagnostic software is intriguing: you start up a program, it performs a series of checks and tests on various parts of the computer, and when it's finished, it tells you how well your computer is operating, and if there are problems that should be attended to. That's something of an oversimplification, of course, and if some part of the computer is totally non-functional so that you can't run the diagnostic program, some skilled technician is going to have to rectify the situation.

Still, diagnostic software is a marvel of current technology. In some cases, it operates a little like those diagnostic flow charts that are a part of so many service manuals today. If there's a signal at this point, then that component must be operational, so check that point next. If that point checks out, observe the presence or absence of a signal at the next point. The software continues to perform those checks in a logical order. Once all the checks have been made, a report is prepared.

To some people, making a diagnosis, whether it's done by a human, a machine, or a software program, seems almost like a mystical procedure. Somehow the diagnostician senses what is wrong with the patient and determines the proper cure.

---

*"To some people, making a diagnosis, whether it's done by a human, a machine, or a software program, seems almost like a mystical procedure."*

---

Of course every competent technician knows better. There is no mystery to arriving at a correct diagnosis. Diagnosis is simply an exercise in logic. By possessing a great body of knowledge about the subject, and carefully observing the condition and operation of the subject (defective product, patient, whatever), and comparing the actual conditions with the ideal, the person performing the diagnosis can determine what the problem is and suggest a cure.

It's easy to say that, certainly, but not necessarily easy to implement it. When the subject is relatively simple, diagnosis is generally quite simple as well. For example, if the problem is a flashlight that won't work, just about anyone who is at all "handy" could determine what's wrong and fix it. In this case, there's only a handful of working parts: the bulb, the batteries, the switch and the case. What could possibly be wrong? A bad bulb, bad batteries, a faulty switch, a bad connection between the batteries and the case.

Making the procedure even easier is the fact that everything is inexpensive and pretty much standardized. If you suspect that the batteries are bad and go out and buy a set, if you're wrong

*"When the subject is relatively simple, diagnosis is generally quite simple as well."*

you just hang on to the batteries. You'll be able to use them somewhere in some other product.

A personal computer of today stands in marked contrast to the simplicity of the flashlight. Memories contain millions of bits of storage, hard drives contain billions of bits of storage space. Then there's the monitor, itself a complex system, audio systems, modems, printers, scanners and more. Amazingly, these incredibly complex systems are quite reliable. But as with any system, whether electrical, mechanical or human, they do malfunction.

Fortunately, these complex systems are modular, and that can help simplify the diagnosis. If the problem seems to be a monitor problem, the technician, or even the user, can substitute another, known-good, monitor. If a new monitor solves the problem, the cause of the problem has been diagnosed: the old monitor is bad. Now the technician has to determine if the monitor can be repaired for a reasonable cost or if it must be discarded.

The diagnostic approach is similar if the problem is in a printer, a scanner, or some other peripheral device. The technician can either try a new peripheral device with the computer, or try the suspected peripheral device with another computer, or both. This will isolate the source of the problem.

Once it has been determined that the source of the problem is internal to the computer, this is where diagnostic software is particularly useful. Among other things, the software can determine what software settings are in effect within the computer.

*"Once it has been determined that the source of the problem is internal to the computer, this is where diagnostic software is particularly useful."*

For example, if the computer will not communicate with, say, the internet, running a simple diagnostic may show the technician that the computer is not set up to communicate via that port, and may provide him with a means to activate that port.

If the printer won't work, it may be that the wrong port has been selected. Or it may be that the computer is expecting to communicate via a parallel port but the printer is a serial printer, or vice versa. A good diagnostic software package will reveal that problem, and provide the technician with the facility to make the necessary correction.

As we said at the outset, diagnostic software is intriguing. It is also useful. But in the final analysis, there's never any substitute for the diagnostic thought process applied by an experienced and competent technician.

*Mike Conrad Penam*

With service tips  
**over 45,000 tips**  
are available  
**after the first click!**  
your  
information comes  
complete  
**from the start!**



**Service Tips provides**

- 45,000 technical tips
- Multiple solutions for a single symptom
- Contains only information valued by technicians
- Uniform Format
- Includes part numbers, values and locations
- FREE Data exchange program
- Updated daily
- Can be Customized with your own solutions

*distributed exclusively by*



**electro dynamics, inc.**

Leading The Way in the USA™

7 Oser Avenue, Hauppauge NY 11788-3808

**NATIONWIDE TOLL FREE PHONE:  
1-800-I-AM-NICE (800-426-6423)**

**NATIONWIDE TOLL FREE FAX: 1-800-873-2948**

**International Phone: 516-496-4400**

**International fax: 516-496-4166**

Circle (63) on  
Reply Card

## Mobile industry reaches out to new consumers at FUSE '98

The mobile electronics industry reached out to Generation Xers in the South Jersey market during the weekend of June 22 at the new Atlantic City Convention Center during FUSE '98, the largest free public exposition of souped-up cars equipped with the latest in sound, security and other mobile electronics products ever held in the eastern United States.

Held in conjunction with BeachFest, Atlantic City's free entertainment festival, FUSE '98 used attitude and lifestyle to try to create a new market for car sound and electronics by combining the products with live concerts and in-line skating competitions. Sponsored by the Consumer Electronics Manufacturers Association (CEMA) and co-sponsored by Clarion, MTX and Jensen/SoundQuest/Recoton Mobile Electronics, FUSE '98 pooled the resources and efforts of the entire mobile electronics industry.

Several thousand new consumers were exposed for the first time to the full breadth of the mobile electronics industry at FUSE.

"FUSE was an experiment to give the mobile electronics industry a 'cool' factor. The concept of an event like this is excellent. Now we have to refine our efforts and explore new event opportunities that can bring us national media exposure and attendance," said Lloyd Ivey, chairman and CEO of MTX. "As the industry looks to see what events FUSE can team up with for 1999, we'll strategically look to events that already have a dominant reputation within the Generation X market and can give us the media exposure our industry needs to survive."

During the next few weeks, CEMA will search for successful event marketing companies that can bring FUSE and the mobile electronics industry the exposure they need. Once a selection of companies has been identified, CEMA will share its search results with its Mobile Electronics Division members, so members can choose events with which they want to partner. On the final day of FUSE, exhibitors unanimously voted that the

concept of FUSE was good, and that they would like to consider other established events to co-locate with for 1999.

## CEMA and HRRC say WIPO legislation would chill product design and innovation

Testifying on June 5 before the House Commerce Subcommittee on Telecommunications, Trade and Consumer Protection, Gary Shapiro, president of the Consumer Electronics Manufacturers Association (CEMA) and chairman of the Home Recording Rights Coalition (HRRC), warned that H.R. 2281, the World Intellectual Property Organization (WIPO) Copyright Treaties Implementation Act, would chill product design and innovation and recommended three basic changes to address the bill's deficiencies.

Citing three major problems with the legislation — that it makes designers of new devices responsible for responding to and implementing all technical anti-copy measures, outlaws certain design choices regardless of their legitimacy and lacks any clear definition of a "technological protection measure"— Shapiro suggested the following solutions:

- Include a clear provision stating that the legislation does not contain any design mandate that products, or their components, must respond to a technological protection measure unless required by a specific law, such as the Audio Home Recording Act.

- Add a "playability provision" to ensure that consumers can receive the products and the programming that they pay for. This would allow product manufacturers and programmers to mitigate adverse effects on the authorized performance or display of a work.

- Incorporate a definition of "technological protection measure" that works in the real world — either by using the definition incorporated in alternative legislation (H.R. 3048) or developing one through a consensus-based process.

These three changes have been incorporated into amendments proposed by Congressman Rick Boucher.

*(Continued on page 54)*

**Electronic Servicing & Technology** is edited for servicing professionals who service consumer electronics equipment. This includes service technicians, field service personnel and avid servicing enthusiasts who repair and maintain audio, video, computer and other consumer electronics equipment.

## EDITORIAL

Nils Conrad Persson, *Editor*  
(Internet e-mail: [cpersedit@aol.com](mailto:cpersedit@aol.com))  
Alycia Nicholson, *Associate Editor*  
(Internet e-mail: [kirstieest@aol.com](mailto:kirstieest@aol.com))  
Richard S. Moseson, NW2L, *On-Line Coordinator*

## CONSULTING EDITORS

Homer L. Davidson, *TV Servicing Consultant*  
Victor Meeldijk, *Components Consultant*  
John E. Shepler, *Audio Consultant*  
Sam Wilson, *Electronics Theory Consultant*

## PRODUCTION

Elizabeth Ryan, *Art Director*  
Barbara McGowan, *Associate Art Director*  
Edmond Pesonen, *Electronic Composition Mgr.*  
Dorothy Kehrwieler, *Production Manager*  
Emily Leary, *Assistant Production Manager*  
Pat Le Blanc, *Phototypographer*

## BUSINESS

Richard A. Ross, *Publisher*  
Sal Del Grosso, *Accounting Manager*  
Ann Marie DeMeo, *Accounting Department*  
Judith Erickson, *Office Manager*  
Catherine Ross, *Circulation Manager*  
Melissa Kehrwieler, *Operations Manager*  
Jean Sawchuk, *Data Processing*  
Denise Kells, *Customer Service*

## ADVERTISING SALES OFFICE

Electronic Servicing & Technology  
21704 SE 35th Street, Issaquah, WA 98029  
Tel.: 425-557-9611 Fax: 425-557-9612

Evelyn Garrison, *Director of Advertising*  
Emily Leary, *Sales Assistant*

## EDITORIAL CORRESPONDENCE:

P.O. Box 12487  
Overland Park, KS 66212  
913-492-4857



Electronic Servicing & Technology (ISSN 0278-9922) is published 12 times a year by CQ Communications, Inc. 25 Newbridge Road, Hicksville, NY 11801. Telephone (516) 681-2922. Periodical class postage paid at Hicksville, NY and additional offices. Subscription prices (payable in US dollars only): Domestic—one year \$26.95, two years \$49.95. Canadian—one year \$36.95, two years \$69.95. Foreign Air Post—one year \$44.95, two years \$85.95. Entire contents copyright 1998 by CQ Communications, Inc. Electronic Servicing & Technology or CQ Communications, Inc. assumes no responsibility for unsolicited manuscripts. Allow six weeks for delivery of first issue and for change of address. Printed in the United States of America.

Postmaster: Please send change of address notice to Electronic Servicing & Technology, 25 Newbridge Road, Hicksville, NY 11801.

CQ Communications, Inc. is publisher of CQ The Radio Amateur's Journal, Popular Communications, CQ Radio Amateur (Spanish CQ), CQ VHF, CQ Contest, and Electronic Servicing & Technology.

# Help Your Students Launch A Fast-Track Electronics Career

In today's competitive marketplace, the  
**CERTIFIED ELECTRONICS ASSOCIATE**  
exam proves a technician's skills for the workplace.

To register for the CEA Exam, call (800) 722-2857  
or visit [www.sylvanprometric.com/nav.htm](http://www.sylvanprometric.com/nav.htm)

The CEA standards were developed through a combined effort of industry, government and education, spearheaded by the Electronic Industries Alliance. For more than 75 years, EIA has been the national trade organization representing U.S. electronics manufacturing



**CEA Administrator**  
Product Services Department  
2500 Wilson Blvd.  
Arlington, VA 22201-3834

**Other questions?**

Phone: (703) 907-7670  
Fax: (703) 907-7968  
E-mail: [prodserv@eia.org](mailto:prodserv@eia.org)  
Internet: [www.CEMAcity.org](http://www.CEMAcity.org)



Circle ( 2) on Reply Card



# Circuit board and parts handling

by the ES&T Staff

In order to pack so much performance and functionality into today's consumer electronics products, manufacturers reduce the size of what goes into them. They had to make individual components smaller, use integrated circuits wherever possible, and reduce the size of printed circuit boards, which, moreover, means reducing the width of circuit traces. All of this miniaturization has, of course, meant that everything in these products is more delicate, in some cases almost too small to be seen, and in general, presents challenges to the technician who needs to diagnose problems in the product and replace components to fix it.

## Printed circuit boards

Take the printed circuit boards themselves. PC boards are brittle, the circuit traces on some of them are hair fine, and many of the components mounted on the PC board may be susceptible to damage from electrostatic discharge (ESD). All of this means that it's important for technicians to exercise care when handling these subassemblies.

For starters, it's important to take great care in removing a PC board from the product. In order to assure reliable connections, the manufacturer designed the connectors into which the PC boards are plugged to exert a considerable amount of force on the conductive fingers. If a technician becomes impatient in trying to remove a board that seems to be stuck, he could easily damage it. A little flexing is

all it takes to crack one or more of the fine traces on the surface of the board, and it's either ruined or will need to be reworked to restore it to proper operation.

If a PC board is difficult to remove, the correct way to remove the board is to gently press upward and sideways on one edge of the board, then do the same to the other edge of the board, alternating from side to side. This rocks the board in its connector, gradually loosening the board from the connector. However, before removing any printed circuit boards, it's a good idea to look over the manufacturer's literature to see if there are any recommendations on removal.

Once the PC board has been removed from the product being serviced, it should be treated with great care. The manufacturer's literature, or markings on the board itself, should tell you if the board contains any ESD sensitive components. If there are any ESD sensitive devices on the board, or if you're not sure, you should handle the board in such a way as to avoid electrostatic discharges through the board.

## Handling and storage for boards and components

These handling suggestions were developed for manufacturing facilities where PC boards are assembled and soldered, and therefore some of the points may not apply to a service center. Still, it pays to be cautious in the handling of any delicate electronics circuitry, so these suggestions are presented as the situation

that every service center should strive for.

- Always work on PC boards at specially designated work areas.

- Check work areas periodically to make sure that they're ESD safe.

- Make sure that there are no materials that can generate static electricity in work areas; materials such as styrene foam, vinyl, plastics, synthetic fabrics.

- Don't allow smoking or eating in electronic servicing work areas.

- Keep static sensitive assemblies in ESD safe enclosures, bags or boxes when they're not actually being worked on.

- The technician should wear a grounding wrist strap or other ESD grounding device when handling boards and components.

- Always handle PC boards by the edges. If possible, never touch the components, the circuit traces, or the edge connectors with your hands..

- Always handle components by the edges, and never touch the leads. Skin oils from your fingers can cause soldering problems.

- Never use hand lotions or creams that contain silicone. Residues from these products can cause problems with soldering or the application of adhesives. Skin-care products that are formulated to avoid problems with electronic circuits are available.

- Never stack PC boards and assemblies. That could cause damage. If the service center has a lot of PC boards out of products for service at one time, you



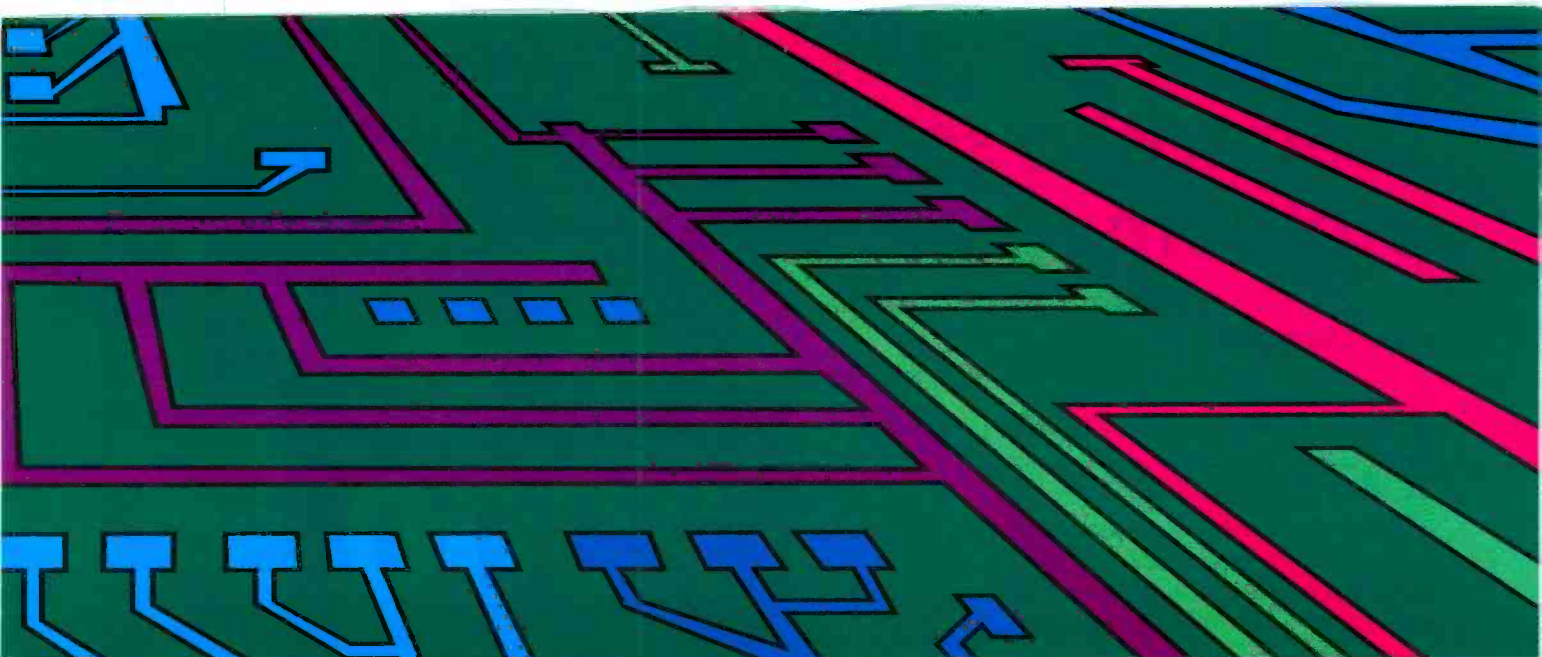

should have racks and trays available for temporary storage.

#### Proper handling pays

Equipping and setting up a service center for safe handling of components and printed circuit boards, and checking peri-

odically to see that it remains safe, takes a certain amount of time, and may require purchasing some special racks and handling products, but that's generally time and money well spent. Some ICs and PC boards are quite expensive, and if the service center has to pay to replace a few of

those each month that were damaged by careless handling, or handling without the proper equipment, that means that some of the profits are going into the scrap bin. Preventing a few of those problems from happening can have a positive effect on the service center's bottom line. ■

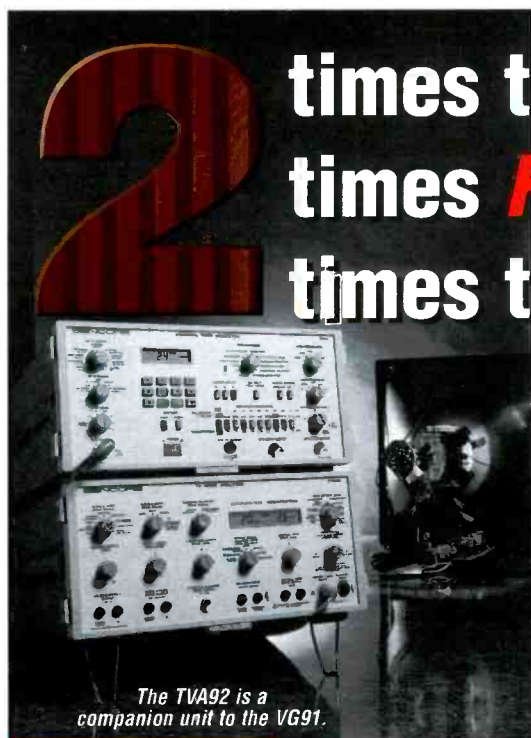

**2** times the **Power!**  
times **Faster!**  
times the **Profits!**

The TVA92 is a companion unit to the VG91.

### Discover How The VG91 And TVA92 Team Up To Improve Your TV Troubleshooting Efficiency

The VG91 Universal Video Generator is the only instrument that provides all the TV-RF and innovative NTSC video tests and signals in one expandable instrument covering all your video servicing and alignment needs.

The TVA92 TV Video Analyzer lets you pull the entire TV together while isolating individual stages. The TVA92 lets you isolate TV defects, troubleshoot startup/shutdown problems, test expensive TV components, plus accurately estimate TV repair costs in minutes.

**Products of the Month – NOVEMBER ONLY!**  
**Call today for individual specials on the VG91 & TVA92.**

**SENCORE**  
3200 Sencore Drive  
Sioux Falls, SD 57107  
(605) 339-0100  
Fax: (605) 339-0317  
www.sencore.com

For more information, call

**1-800-736-2673**

to contact your Sencore Sales Representative.

# Diagnostic software for the Y2K problem

by the ES&T Staff

**B**ack in the dim and distant early days of computers when computers were used as computers; to calculate the results of mathematical expressions, the components that comprised the computer's memory were large and expensive. The amount of memory that a computer could have was, therefore, quite limited.

Because the memory was limited, it was a challenge to programmers to make the programs they wrote as compact as possible. Some programmers took great pride in writing a program, then inspecting and editing until they could get their program as lean as possible.

## Making the year compact

Unfortunately, this mania for compactness led to some problems that will soon affect the world in a big, unknown, way. Most of us have become used to abbreviating the year to two digits. It's now 1998, but as often as not, we simply write 98. If I say something about the year 54, you will know that I mean 1954.

That's pretty much what early programmers did. A lot of early computing had to do with business operation: banks, for example.

Let's take a look at what a typical bank record might consist of. Using a relational database, the bank would maintain one record of customer information including name, address, telephone number, account number, etc. Then each transaction in each account would create a separate record, related to the customer's personal information by the account number.

When the bank performs certain calculations, let's say accrued interest on a savings account, the date is important. It tells the computer how long the money has been in the account, and therefore, how much interest has accrued. Part of every date in every transaction record in the computer's memory is the year.

The year is a four-digit number. If

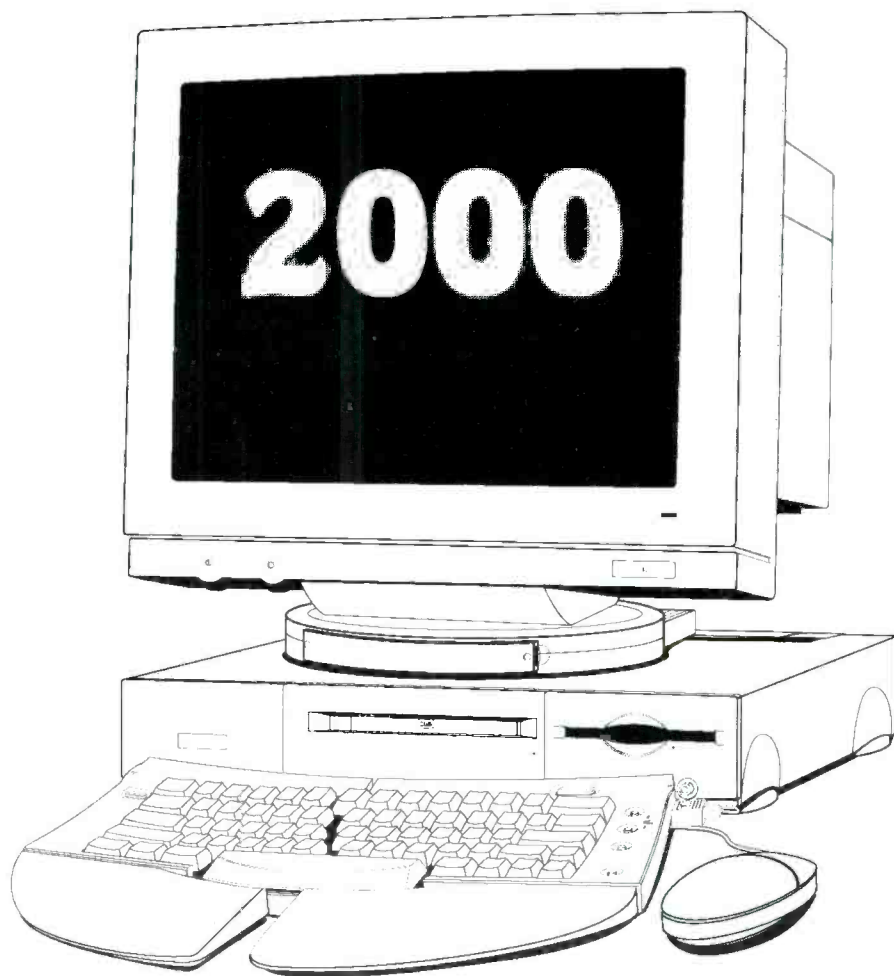

instead of using four digits to record the year for every transaction for every customer in the bank, we used only the last two digits, think of how much memory space we could save. That's precisely how those early programmers thought.

## A new century

The use of a two-digit year was fine as long as the century digits remained the same for all records. When the computer wants to calculate your interest for, say, a year, it subtracts the previous year's date from the current date to use for the period during which the interest accrued. For example, to calculate your accrued interest for the year 1998, on January 1, 1999, the computer would use some kind of algorithm to subtract, say, 01/01/97 from 01/01/98. Nothing could be simpler.

But what happens when it does that the following New Year's Day. The computer is going to try to subtract 01/01/99 from 01/01/00. You and I could do that in our heads. We know that 00 will mean 2000. The computer does not. Computers are not as intuitive as people are. They are very literal. To computers that have not been set up to handle this problem, any entry that includes the year 00 in the two-digit place in the computer's memory, means 1900. Yikes.

---

***“To computers that have not been set up to handle this problem, any entry that includes the year 00 in the two-digit place in the computer's memory, means 1900. Yikes.”***

---

Just for the record, this problem has been called: the Y2K (for year 2000) problem, the Millennium Bug, and other such grand names. Actually, it's not a thousand year problem, such as these names suggest, but a hundred year problem. If computers had been invented in about 1840 instead of about 1940, the problem would have reared its ugly head when the century changed from 18 to 19. The two-digit date would have still changed from 99 to 00, confusing the computers.

### Compiled code adds to problem

Companies have recognized this problem for some time, and some have made great strides in trying to correct it. If it were only necessary to replace every two digit year with a four digit year, it would be easy (relatively).

Unfortunately, adding to the problem is the fact that many of the programs written for computers were written in "compiled" languages, such as COBOL. The original, "source," code written by the programmers in an English-like programming language may have included year's digits information. When the program was "compiled," converted from that English-like language to the language of the computer, it was completely changed. And compiling is a process that is not totally reversible. You can't run a compiled language through a decompiler and get the original source code back.

Adding more to the problem, as often happens over decades, much of the original source code that was written and then compiled was either lost or discarded. So finding the places in a compiled program that represents the years digits is a daunting problem.

### What will happen

The problem is such that huge numbers of articles have been written on it, and as the date 01/01/00 comes closer and closer, more concern will be voiced. Once the next New Year's day comes around, people will realize that there will be only 365 days, 52 weeks, 12 months to do something about the problem.

Some people are predicting dire occurrences on January 1, 2000 because no one knows for sure what will happen to computers on that day. Some experts recommend that people not fly on that day, that people take some cash out of the bank and

---

***"Professionally, the greatest concern for consumer electronics service in all of this is the question of what will happen to personal computers."***

---

keep accurate records of what's in the bank. Some have predicted that many products, such as automobiles, TVs, VCRs; the list goes on and on, that are controlled by computers will not work.

Other people and organizations, such as, say, the Consumer Electronics Manufacturers Association, are saying that imbedded computers in consumer products will not be a problem.

### The implications for personal computers

Professionally, the greatest concern for consumer electronics service in all of this is the question of what will happen to personal computers. Will the service center's computer, or the personal computers of clients operate when they're turned on on January 2, 2000.

Actually, the question is several fold. The first part of the question is, will the computer operate at all? There is some

---

***"Then comes the question, how about the applications software, such as database programs. Do those programs allow only two-digit dates, or can the user enter four-digit dates?"***

---

concern that some computer BIOSs (basic input/output system) may be date dependent, and when the year 2000 comes, this component may cause the computer not to operate, or to operate unreliably. There is also concern about operating systems; the software that makes the computer operate. If your software is date sensitive, it may not operate when the computer's clock says 00.

Then comes the question, how about the applications software, such as database programs. Do those programs allow only two-digit dates, or can the user enter four-digit dates? And how has the data been entered until now? If the user has been using two-digit dates, this might be a good time to convert those and future dates to four digits.

### Diagnostic software for Y2K

Fortunately, a number of software manufacturers have been working on the problem and have come up with programs that can perform a diagnosis on any personal computer and determine whether it will or will not survive the transition to the year 2000 without problems.

### More to come

It was the intent of this article merely to make readers aware of this problem and the fact that there are diagnostic software solutions to it. Future articles will explore how serious this problem may be to personal computers, and will provide some specific information on where to go to find software that may ameliorate or solve the problem. ■



# Extending soldering iron tip life

by Edwin Oh and Doug Wilkerson

Even under normal usage, the plating on all soldering iron tips will eventually fail. Plating life depends on the soldering application, the type of fluxes and solder used, and, most important, operator technique. Because of this, manufacturers of soldering iron tips do not generally warrant plating life.

Tip plating failures for all solder tips can be divided into four main classes.

- Stress/Cracking
- Corrosion
- Dewetting
- Wear/Abrasion

Before discussing each of these in detail, it is useful to understand how a typical soldering iron tip is constructed.

## Tip plating

A tip typically consists of a solid copper core, a plated layer of iron, a plated layer of nickel behind the working surface, and a plated chrome layer (Figure 1). Copper is used for the core, primarily to ensure good heat transfer. The nickel layer is a non-wetting layer designed to keep the solder from wicking away from the tip's working surface. Without this layer, the solder would travel preferentially up the tip toward the heat source, making it impossible to apply solder to

the solder joint. The chrome layer is applied as an additional protective layer.

The key working layer, and the one that affects tip life the most, is the iron layer. Most plating failures are a failure of the iron. The iron fails in a different way for each failure mode. It is important to understand which failure mode is occurring, so that the proper corrective action can be applied. For example, it is common for people to believe that simply putting more iron on a tip will improve tip life. While applying more iron may help prevent wear-related failure, it would not help prevent the problems of dewetting or cracking.

Iron, like any material, has its strong and weak points. Soldering iron tip manufacturers have investigated a number of alternative materials; however, to date, iron has had the best combination of properties for use in soldering applications.

## Why iron plating?

Why has iron been chosen universally by all solder tip manufacturers as the working surface material for a solder tip? To answer this question, we must examine the material requirements for a solder tip.

## Good heat transfer properties

As transfer of heat is the primary task of a soldering iron, it is not surprising that a solder tip material must have good heat

transfer properties. For the most part, this means that metals must be used (as opposed to ceramics, for example, which may have better mechanical properties but are thermally insulative). Iron has acceptable transfer properties, but copper is better (which is why solder tip cores are made of copper). So why not make copper solder tips?

## Must not dissolve in molten solder

Most commercial solders are some binary or ternary combination of tin and lead. Molten tin will rapidly dissolve most metals, including copper. So a protective layer must be applied that won't dissolve so rapidly in tin. Iron is one of the few metals that can resist exposure to molten tin for any period of time. But molybdenum also resists tin dissolution and has even better mechanical properties than iron. So why not use molybdenum?

## Must be wettable

The working surface of the tip must wet to transfer molten solder to the joint and to aid heat transfer. Iron wets. Molybdenum doesn't.

## Must have good physical/chemical properties

Good physical/chemical properties include abrasion resistance, ductility (for crack resistance), melting point, etc. Iron,

Oh is Director of Marketing, and Wilkerson is Technical Services Manager for Metcal.

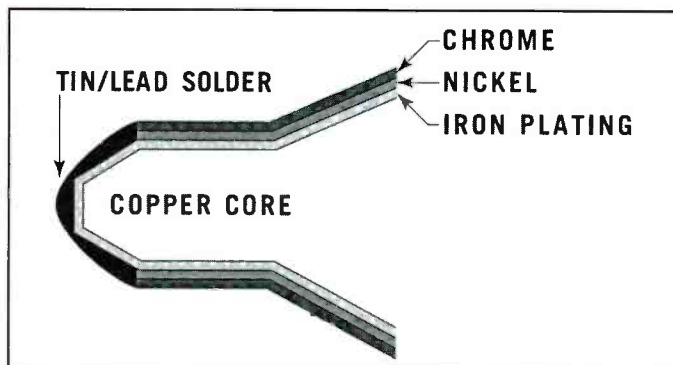

Figure 1. A soldering iron tip typically consists of a solid copper core, a plated layer of iron, a plated layer of nickel behind the working surface, and a plated chrome layer.

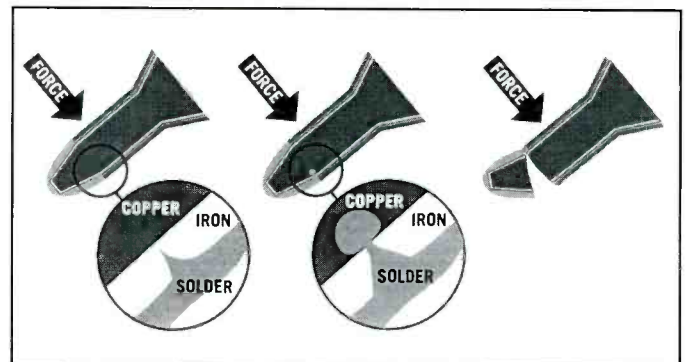

Figure 2. If the iron plating on the soldering iron tip cracks, once the copper core is exposed, solder will quickly dissolve some of the copper away, hollowing out the tip.

**Cracking:**

Select the largest tip possible for the lead being soldered.  
Do not apply excessive pressure when soldering. To maximize heat transfer, tin the tip.  
Take care not to bang the solder tip against the metal workstand when inserting the tool.  
Do not use tips as a screwdriver or a prying tool.

**Wear:**

Select the largest tip possible for the lead being soldered. Blunter tips carry more plating.  
Do not apply excessive pressure during soldering.  
Do not "scrub" the lead. To maximize heat transfer, tin the tip and create a solder bridge.  
Do not drag solder. If you must drag solder, be aware that it will shorten tip life.  
Do not use commercial tip tanners for routine tinning. Use a flux core solder wire or paste.  
Use a clean, wet sponge to clean the tip. Do not use a dry sponge, rag, or any abrasive.

**Corrosion:**

Select lower activity fluxes where possible. RMA flux is best for maximum tip life.  
Use only sulfur free sponges for cleaning tips.  
Use only clean sponges. Discard dirty sponges.  
Use RMA solder to tin tips during storage. Do not use aqueous or high activity flux solders.

**Dewetting:**

Turn the system off when not in use.  
Use the lowest possible temperature when soldering. Low temperature reduces oxidation.  
Keep tips tinned when in use and during storage. This keeps air from the tip.  
Use a flux with suitable activity during soldering. Use only clean sponges. Use deionized water to wet the sponges.

**No Clean Solders:**

Use the lowest possible temperature. Low temperature reduces thermal oxidation, solvent volatilization, and polymerization.  
Periodically use an RMA wire solder or solder paste to tin the tip.

**Heater Care:**

Do not use pliers to change tip cartridges. Use a Cartridge Removal Pad.  
Do not drop tip cartridges onto hard surfaces.  
For surface mount tips, do not bang the tips to dislodge components.  
Use a sponge.

**Table 1.** Recommended tip cartridge care guidelines.

while not the best in any category, has acceptable mechanical properties.

**Must be processable**

Iron can be applied to a copper substrate with good adhesion by a number of techniques. Electroplating is the most common method. For today, iron best meets all of the criteria for a desirable material for plating soldering irons.

**Stress/cracking failures**

Plating failure due to cracking is caused by too much stress being applied to the tip during soldering. Usually, operators apply too much pressure on the tip, mistakenly believing that applying more force to the tip will aid heat transfer. This

is incorrect. The best ways to ensure good heat transfer are to use the largest tip possible on the lead that allows good access (maximize contact area), to tin the tip well, and to use molten solder as a thermal bridge between the tip and joint.

While iron plating has many good properties, fracture toughness is not one of them. Too much force applied to the plating layer will cause a crack to form. This crack will propagate all the way through to the copper core, in much the same way that cracking a block of ice causes the ice to split. Due to this crack propagation, a thicker plating of iron will not cure this problem.

Once the copper core is exposed, solder will quickly dissolve it away, hollowing out the tip (Figure 2). At some

point, the iron plating, unsupported by copper, snaps. A sure sign of a stress/cracking failure is a hollowed out or jagged soldering iron tip.

Banging the tip against a workstand is another way to crack iron plating. This can be prevented by taking care not to hit the tip against the workstand when reinserting the solder handle. To help guard against this problem, some workstands have phenolic plastic inserts. The softer plastic is more forgiving than metal, should the tip accidentally strike it. However, even with plastic, a carelessly struck tip may still crack.

Cracked plating tends to be more common with fine point tips, which are more susceptible to the mechanical stresses that can lead to cracking. Wherever possible,

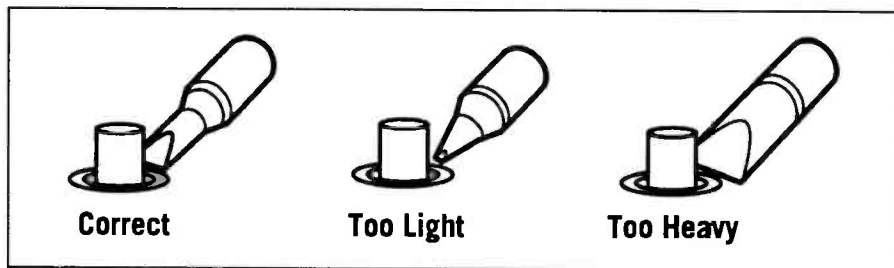

**Figure 3.** Wherever possible, the largest tip that maximizes contact area between tip and lead should be selected. This will maximize heat transfer, reducing the tendency to try to speed up soldering by applying too much force to the tip.

the largest tip that maximizes contact area between tip and lead should be selected (Figure 3). This will maximize heat transfer, reducing the tendency to apply too much force to the tip. Also, larger tips can withstand more force.

Soldering iron tips can also be easily damaged when they are used for a job for which they were not intended. They should never be used for prying clinched leads, as a screwdriver, or as a can opener. There is a reason pliers and screwdrivers — the proper tools for these jobs — are made of hardened steel alloys. Soldering tips cannot withstand the harsh mechanical abuse these tasks entail.

### Corrosion failures

Corrosion induced plating failures are primarily related to the flux being used with the solder. Iron, like many metals, can be attacked when exposed to acids. Fluxes generally contain some form of halide additive or organic acid material. They are designed to chemically strip away iron oxides when brought to soldering temperatures. Unfortunately, some of the more active fluxes will also attack iron. One common class of fluxes, aqueous clean fluxes, appears to cause a high incidence of corrosion failures, since they are highly active and typically contain an organic acid (like citric acid). However, flux chemistry varies greatly according to manufacturer. Consult your flux, solder wire, or solder paste supplier for more details.

When selecting a flux, you should not only take into account long-term solder joint reliability, post assembly cleaning costs, in-process effectiveness, environmental considerations, etc. You should also take into account the effect on solder tip life, which has a direct bearing on operating costs.

Strictly from the standpoint of tip plat-

ing corrosion, the less active the flux, the lower the chance that the plating will be eaten away. Figure 4 shows an activity ranking of various flux types. RMA fluxes have proven to yield the best tip life.

Corrosion related failures can further be reduced by making sure sponges used to clean tips are sulfur free. Only use sponges carried by a reputable solder supplier designed for soldering. Regular

“store” sponges often contain sulfur or plastic materials that form corrosive byproducts when the sponges are heated to soldering temperatures.

Use only clean sponges. Dirty sponges collect contaminants which then can react at high soldering iron tip temperature, forming corrosive byproducts.

Also, when tinning a tip for storage, use an RMA or other low activity flux core solder. Do not use aqueous clean or organic acid flux core solders, as these can corrode the tip during storage.

### Dewetting failures

Dewetting is the most common form of plating failure and is preventable, for the most part, with good daily tip care. Thermal dewetting is caused by oxidation of the iron plating. The plating turns to iron oxide, which is non-wetting. A dewetted tip can be identified by the fact that solder

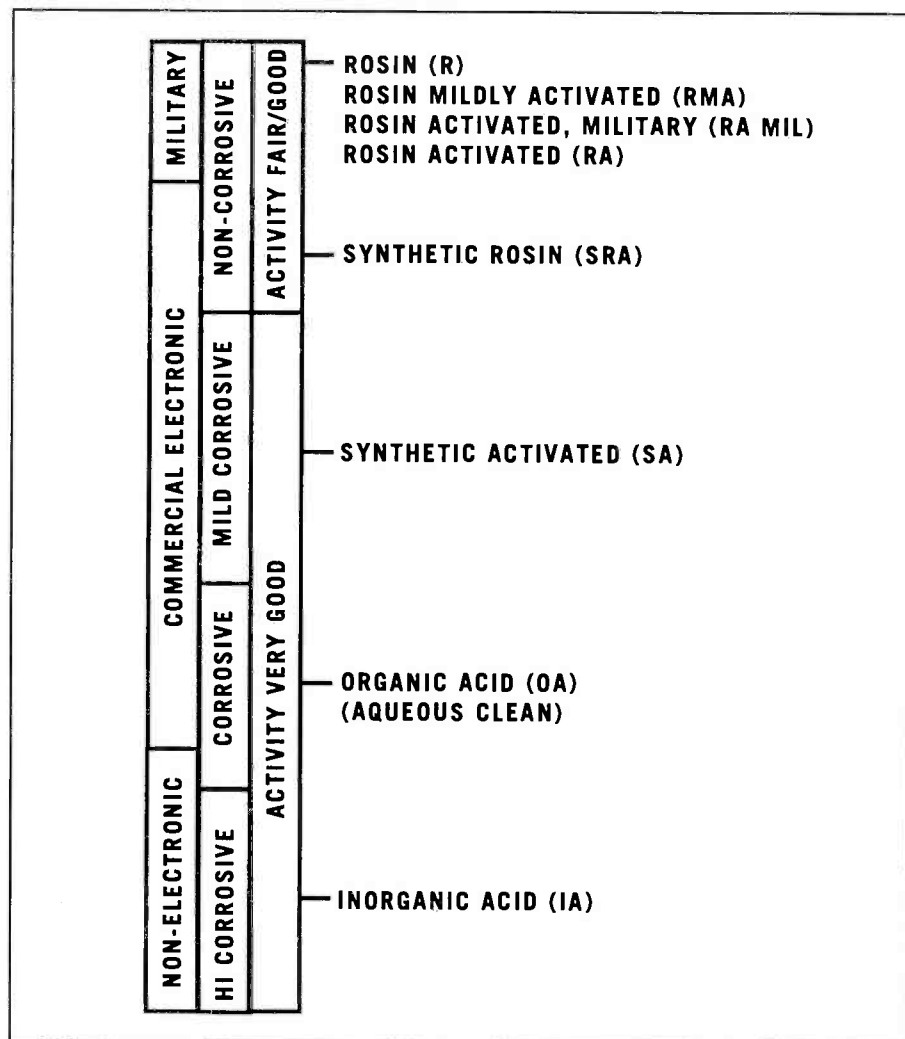

**Figure 4.** From the standpoint of soldering iron tip plating corrosion, the less active the soldering flux, the lower the chance that the plating will be eaten away. Shown here is an activity ranking of various flux types. RMA fluxes have proven to yield the best tip life.

will not flow evenly across the working surface of the tip. Instead, solder applied to the tip will tend to ball up (like mercury from a broken thermometer). In addition to shortening tip life, dewetting impairs heat transfer. The oxide build-up acts as a thermal insulator. Frequently, the complaint that a soldering iron tip "isn't hot enough" is really a dewetting problem.

Iron oxidation occurs naturally during the soldering process. The reason flux is used is to strip off oxide build-up on the tip and the leads to allow a solder joint to form. Because oxidation is a function of temperature and exposure to the oxygen in the air, the way to minimize oxidation is to keep the tip tinned (which covers the iron plating with a protective blanket of solder) and to solder at lower temperatures whenever possible.

A thicker iron plating on the tip would not fix this problem, as it is the surface of the plating that oxidizes. The keys to preventing oxidation and dewetting are lower temperatures, regular tinning, and a suitably active flux.

The single most effective way to minimize oxidation and extend soldering iron tip life is simply to turn the system off

when not in use. The rate of oxidation at room temperature is negligible compared to what it is at soldering temperatures. Turning the system off during breaks can result in an immediate 10% to 15% increase in tip life.

Using the lowest possible temperature during soldering will reduce oxidation and extend tip life. There is a tendency to solder at higher temperatures than needed. Not only does this shorten tip life, it needlessly increases the risk of PCB damage.

Oxidation can also be controlled by limiting the exposure of the solder tip to air. The best way to do this is to keep the tip tinned when stored. This shields the iron plating from the oxygen in the air.

Dewetting can also occur if the flux being used is not active enough, or if no flux is used. This is typically the case with "No Clean" solders. Currently, the most common tip plating failure associated with "No Clean" solders is dewetting. Tip dewetting while using no clean solders is not a problem caused by the soldering iron tip. It is a process problem involving the interaction between the tip, flux, solder, and temperature.

Dirty sponges are one further cause of

dewetting. In addition to the corrosive byproducts mentioned earlier, dirty sponges collect solder dross that contain heavy metals. This dross can adhere to the iron plating forming a non-wetting surface. Hard water also contains elements which can form a bonded, non-wetting surface. To prevent this, use only clean sponges wet with deionized water.

Should a tip become detinned, it can be restored by use of a commercial tip tinner. These products contain an abrasive used to strip the oxide and can be used to squeeze out more life from a ruined tip. Unfortunately, this same abrasive will also remove some of the iron plating, as well as any oxide, shortening tip life. Therefore, the best practice is not restoration, but prevention.

### Wear/abrasion failures

Plating failure due to wear is the only unpreventable failure mode experienced by all soldering iron tips. In a sense, plating wear is the "proper" mode of failure for a tip. The other failure modes discussed are preventable with care. Normal wear is caused by the abrading away of the iron plating as the tip comes into con-

**Stop Unsoldering**  
**- Analyze In-Circuit!**  
**New!**

**ReZolver**

Now, reduce the number of capacitors and inductors you unsolder for good/bad testing or replacement by 50% or more with the new LC103 "ReZolver"™.

How often do you unsolder capacitors and inductors only to find they test good or a replacement doesn't solve the problem? The Sencore "ReZolver"™ offers exclusive in-circuit analyzing tests guaranteed to reduce unsoldering time and avoid costly surface mount component replacement.

The "ReZolver"™ features in-circuit value and ESR tests on capacitors from 0.02 to 20,000 µF. Innovative tests sense parallel components for error free results. An Adjustable In-Circuit Test Probe provides reliable connections, push-button test ease, and frozen display measurements.

**Give us a call at 1-800-SENCORE for a FREE Tech Tip showing how the LC103's exclusive in-circuit tests will catch more defects than any other tester on the market.**

**SENCORE**  
3200 Sencore Drive, Sioux Falls, SD 57107  
Direct: (605)339-0100 Fax: (605)339-0317  
www.sencore.com email:sales@sencore.com

# ES&T Calendar

WIRED Technology Expo  
(WIRED Magazine)  
November 7-8, 1998  
Tarrant County Conv. Center  
Fort Worth, TX  
Julie Garinger/Bruce Rabin (TX):  
817-263-4041

COMDEX/Fall '98  
November 16-20, 1998  
Las Vegas Conv. Center and Hotels  
Las Vegas, NV  
<http://www.Comdex.com>

Int'l. Cons. Electronics Show (CEMA)  
January 7-10, 1999  
Las Vegas Convention Center and  
Hotels  
Las Vegas, NV  
CEMA (VA): 703-907-7600  
[www.cemacity.org](http://www.cemacity.org)

Western States Conference  
(Regional Associations Conference)  
Feb. 18-20, 1999  
Queen Mary  
Long Beach, CA  
Bob Lunn (AZ)  
Phone/Fax: 602-943-0596  
[Lunnct@aol.com](mailto:Lunnct@aol.com)

1999 All Service Convention  
March 10-14  
Radisson Resort Parkway Hotel  
Orlando, FL  
Sponsoring Associations:  
Professional Service  
Association — PSA  
Electronics Technicians  
Association — ETA  
Florida Electronic Service  
Association — FESA  
Satellite Dealers  
Association — SDA ETA  
604 N Jackson, Greencastle, IN 46135  
765-653-8262  
Fax: 765-653-4287  
e-mail: [eta@indy.tdsnet.com](mailto:eta@indy.tdsnet.com)  
web site: <http://www.eta-sda.com>

Tri-States Annual State Convention '99  
March 11-14, 1999  
Hood River Inn  
Hood River, OR  
Mike McCray (OR)  
503-288-5356  
Fax 503.288.0359  
[mmccray@cowboyz.com](mailto:mmccray@cowboyz.com)

Electronic Distribution  
Show: EDS '99  
May 18-20, 1999  
Educational Programs May 17th  
Las Vegas Hilton Hotel  
Las Vegas, NV

National Professional Service  
Convention  
August 2-7, 1999  
(Trade Show August 4 and 5)  
Hotel Intercontinental  
Dallas, TX

PCS 99  
September 22-24, 1999  
New Orleans, LA  
703-739-0300

Consumer Electronics Manufacturers  
Association (CEMA)  
2500 Wilson Blvd  
Arlington VA 22201-3834  
703-907-7600  
<http://www.cemacity.org>

Electronic Distribution Show  
Corporation  
222 South Riverside Plaza, Suite 2160  
Chicago, IL 60606  
(312) 648-1140  
Fax: (312) 648-4282  
<http://www.edsc.org/>  
[eds@edsc.org](mailto:eds@edsc.org)

NESDA  
2708 W. Berry  
Fort Worth TX 76109-2356  
817-921-9061  
Fax: 817-921-3741  
<http://www.nesda.com>



tact with solder joints. A worn tip will typically show a hole on its working surface.

Wear life is affected by two things: plating thickness and operator practice. Plating thickness is limited by tip geometry and thermal responsiveness. Too thick a plating can limit the thermal responsiveness of the soldering iron.

In addition, fine point and slim tips cannot carry as much iron plating as blunter tips, without losing their sharp profiles. Tip life can often be extended simply by selecting a blunter over sharper tip whenever possible. Fight the common tendency to pick the finest tip. Often, the blunter tip is the right tip.

Wear can be minimized by not applying excessive force during soldering, and by not "scrubbing" the tip against the joint. As in the case of excessive force, operators often believe incorrectly that "scrubbing" aids heat transfer. It does not.

Drag soldering will cause tips to wear out faster. Drag soldering is equivalent to running a soldering iron tip across a metal file. Besides accelerated tip wear, drag soldering on through-hole leads is a questionable practice with respect to solder joint quality. Because the solder tip spends almost no time on the lead, the solder joint may have insufficient time at the proper temperature to form a strong bond (resulting in a weak, brittle, or cold joint).

Occasionally, commercial tip tinner are used during normal soldering operations for reasons of convenience. This should not be done. Commercial tip tinner are designed to restore detinned tips to working condition and contain an abrasive. They are not meant to be used for routine tinning. The abrasive will cause excessive wear of the iron plating. For routine tinning, a flux core solder wire or flux bearing solder paste is recommended.

Finally, never use an abrasive material like sandpaper, emery cloth, rags, or dry sponges to clean a soldering iron tip. Use a clean, wet sponge.

If there is a buildup of solder or residue on the tip, you may want to use a brass brush to clean the buildup.

## Summary of soldering tip cartridge care guidelines

By following the proper care practices as part of your daily habit, you should be able to enjoy maximum soldering tip life. Table 1 summarizes recommended tip cartridge care practices by type of failures. ■



# Microwave oven repair basics

by John Ross

As with all electronic devices, the prices of microwave ovens have plummeted in years. Although microwave ovens offer relatively simple repair tasks, it is important that technicians remain equipped with a fundamental knowledge base before attempting the repair. With this knowledge base in hand, technicians can spend less time performing the actual repair and, as a result, obtain higher profit margins. The following article uses an example microwave oven to show how components function and to illustrate basic repair solutions.

## Microwaves and microwave ovens

A microwave is an electromagnetic wave of radiant energy that has a length between 1 meter and 1 millimeter. Wavelength equals the speed of light divided by the frequency. As with light waves, microwaves travel in a straight line and can be generated, absorbed, reflected, and transmitted. Aluminum and stainless steel reflect microwaves while cold-rolled steel, water, and food absorb microwave power. The perforated holes in the door of a microwave oven reflect microwave power and transmit light. Glass and china products transmit and absorb microwave power.

The Federal Communication Commission limits the design of microwave ovens because of the possibility that the operating frequency of the oven could interfere with communications devices. For that reason, the FCC has allocated microwave frequency bands that may be used for the operation of a microwave oven. While additional band allocations exist, the most popular are 915MHz, 2450MHz, and 5800MHz. When we consider the relationship between wavelength and frequency and the normal 2450MHz operating frequency of modern microwave ovens, we find that the wavelength of the microwave used in an oven is approximately 4.7 inches.

## Microwave components

Every microwave oven contains both mechanical and electrical components.

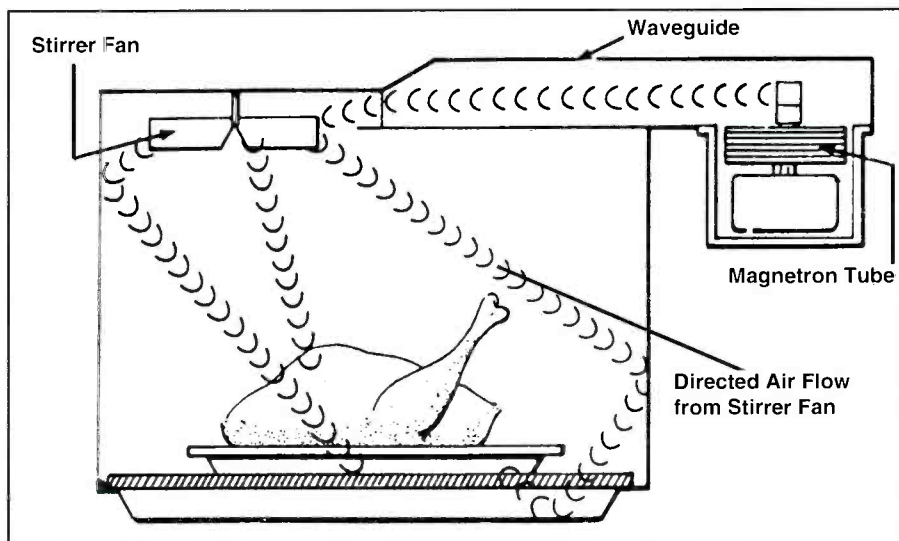

Figure 1. Waveguide assembly and stirrer fan airflow.

The *oven cavity waveguide* assembly (Figure 1) forms from the oven sides, bottom, front frame, oven back, and oven top. Recessed wells at the top and bottom of the oven allow the glass tray to hold the food above the oven bottom and the stirrer fan to recess into the oven top.

The *stirrer assembly* usually consists of a stirrer fan, bushing, and a drive wheel that attaches through a pulley and belt assembly to a drive motor. The stirrer fan changes the microwave field emitted by the magnetron tube so that an even power distribution occurs. Without the stirrer

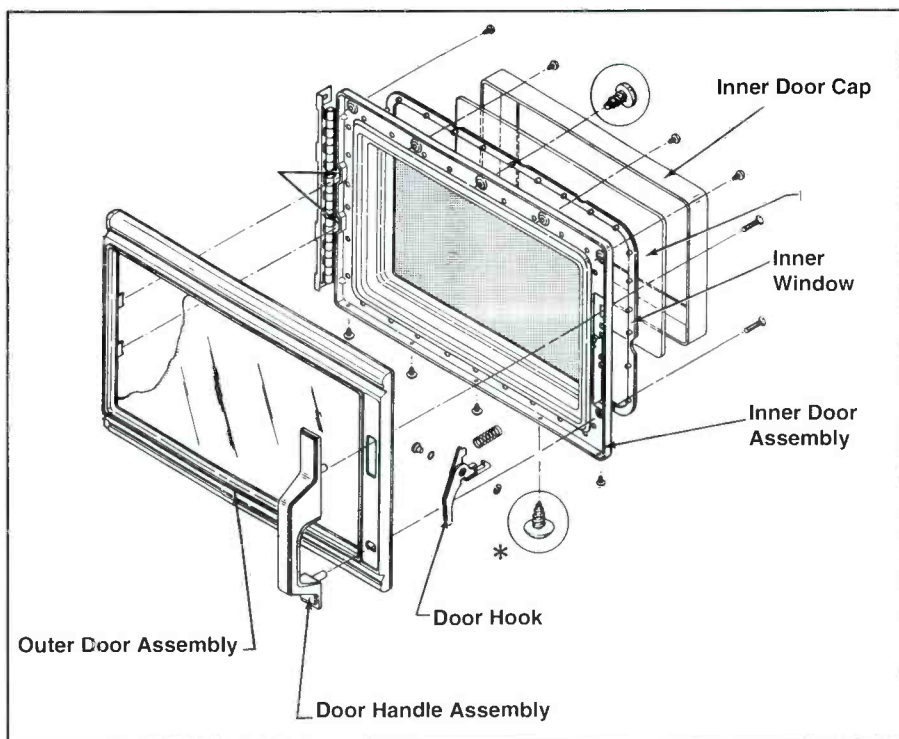

Figure 2. Microwave oven door assembly.

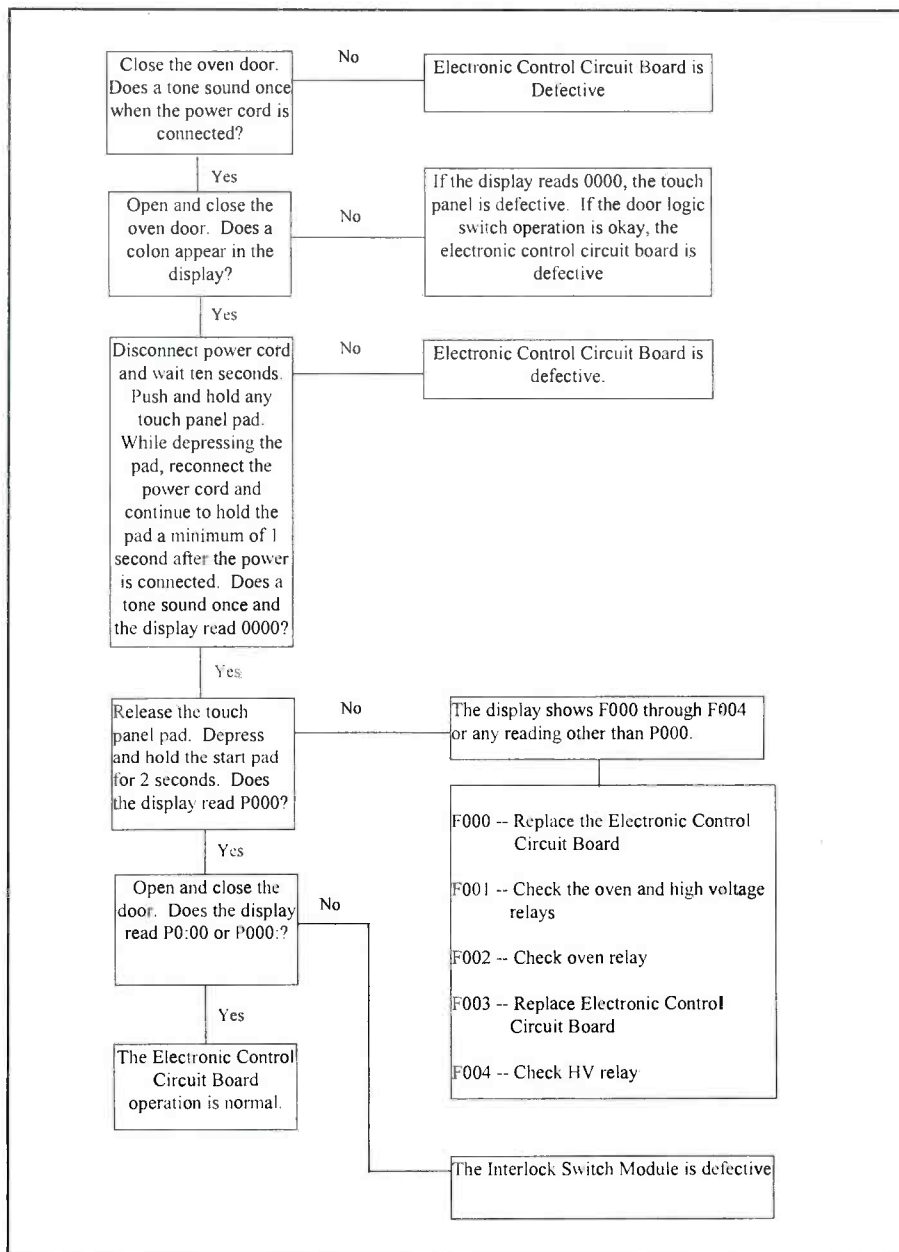

Chart 1. Electronic Control Circuit Board Problems and Solutions

fan, the power will concentrate on one or two hot spots within the oven.

*Microwave oven door assemblies* have five parts: the end cap; the dust cover; the door frame; the door latch; and the door strike. The end cap (Figure 2) typically attaches to the door through three screws and fits over the dust cover. In addition to allowing the removal of the dust cover, the removal of the end cap also exposes the door latch screws and the door strike. In most cases, the removal of the complete oven door is unnecessary. However, the alignment of the door affects the operation of the door switch assemblies.

Microwave leakage can occur through an improperly aligned door and should be monitored with a radiation detector meter.

### Monitoring radiation leakage

As mentioned, a radiation detection meter is necessary for the measurement of potential radiation leakage at specific points around the microwave oven door. During the test, place a water load of approximately 1-1/3 cups in the oven; operate the oven at a high setting; and slowly move the meter probe along the door areas. When using a dual-range monitor, use the high range to avoid dam-

age to the instrument during power peaks caused by a rotating stirrer fan. Use the low range for low-level readings.

### Microwave electrical components

The magnetron tube attaches to the waveguide through four threaded studs (Figure 3). A wire mesh gasket on the tube forms a seal between the tube and waveguide once the nuts are tightened. Magnetron tubes require two different electrical inputs for operation. A filament circuit, which consists of a coil of heater wire around the cathode, connects to two terminals and heats the cathode of the tube. An open heater wire or the loss of the 3.15Vac at this point will cause the loss of the magnetron operation.

The second electrical circuit connects between the cathode and the plate. With the case of the tube acting as the plate and at ground potential, the cathode connects to one of the filament terminals. Rather than using this plate-to-cathode connection to allow the magnetron to act as a rectifier tube, a half-inch air gap exists between the cathode and plate and creates a condition in which a magnetic field influences the direction of the electrons. A magnet built around the tube has enough of a field to turn the electrons at a right angle and to cause an electron flow in a circular pattern.

Because the magnetron consists of tuned cavities, oscillation occurs. Electrons passing in front of the cavities cause the electrons within the cavities to oscillate at 2450MHz. With the cavities connected to the antenna of the magnetron, the resulting microwaves are broadcast into the oven.

### Testing the magnetron tube

The test procedures for a magnetron tube involve milliamperage current tests and non-operational tests. With the first test, we measure the dc cathode current of the tube during operation. Before connecting or disconnecting test leads, always ensure that the power for the oven is disconnected. In addition, use a voltmeter with a 0.5Vdc scale or higher.

To begin the test, place a one or two cup water load in the oven; select the full power setting for the oven; and set the oven timer for three to five minutes. With the negative lead of the meter connected to the chassis ground and the positive lead con-

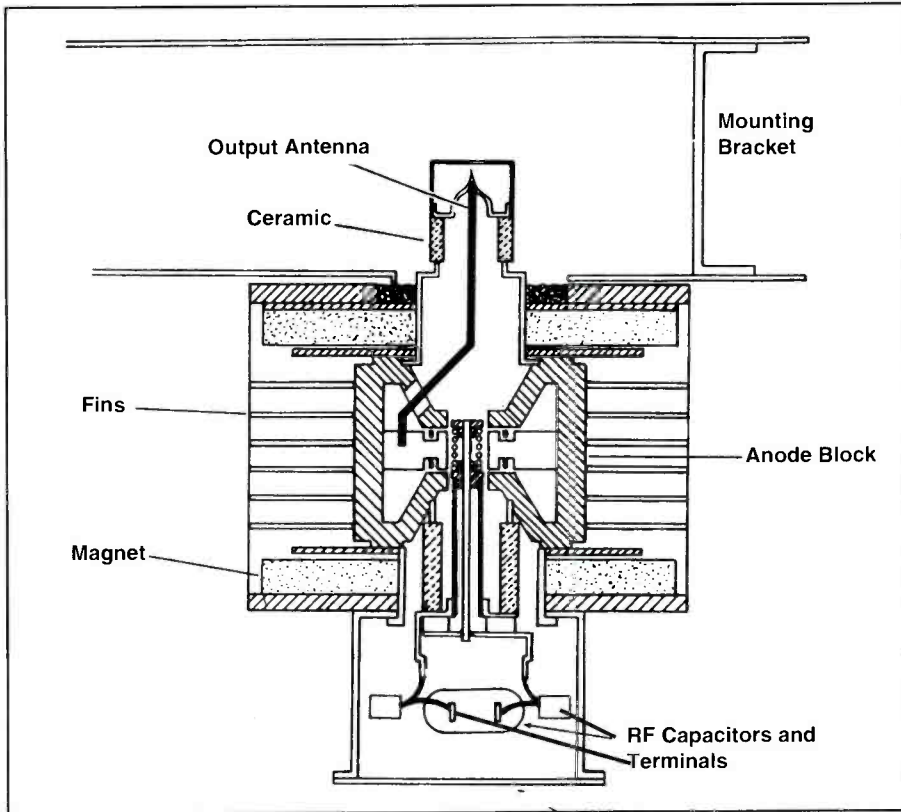

Figure 3. The magnetron tube attaches to the waveguide through four threaded studs.

nected to the appropriate test point, apply power to the oven and observe the meter indication. More than likely, the appropriate test point will be located between the ground end of the rectifier diode and a ground resistor located in the high voltage transformer secondary circuit.

During the first few seconds of operation, the meter reading for a low power magnetron, such as those used in older range/oven combination units, should show approximately 2.8Vdc to 3.1Vdc. Higher power magnetrons will require approximately 8Vdc. From there, we can

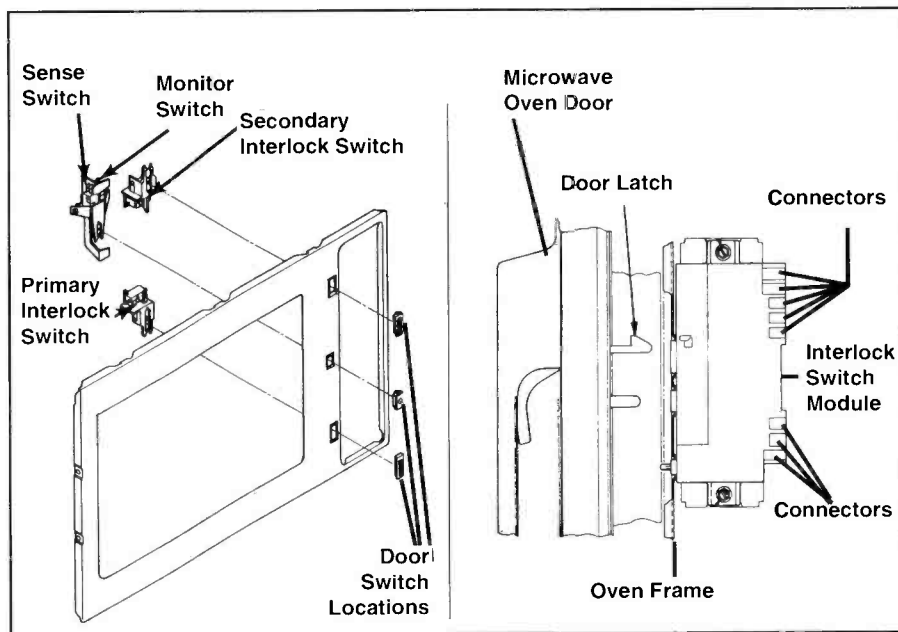

Figure 4. Drawing A shows the door switch assembly. B shows the interlock switch module.

# CAPACITORS

ARE THE LEADING CAUSES OF FAILURE IN TVs & VCRs.

CHECK CAPACITORS IN-CIRCUIT WITH 100% ACCURACY IN SECONDS

CapAnalyzer 88 \$179



- Automatically discharges capacitor, Checks for low DCR and shorted caps, Checks high-frequency ESR and displays on 20-segment LED meter.
- 3-color chart shows typical readings.
- Includes gold-plated tweezer probe.
- Portable... Batteries included!

LOCATE ANY SHORTED or LEAKY COMPONENT TO THE EXACT SPOT  
LeakSeeker 82A \$179



Locates shorts with NO cutting up the PC board or unsoldering any parts!  
60 DAY MONEY-BACK GUARANTY

AVAILABLE AT YOUR DISTRIBUTOR



ELECTRONIC DESIGN SPECIALISTS  
4647 Appalachian St, Boca Raton, FL 33428  
www.eds-inc.com 561-487-6103

*we make test equipment designed to make you money.*

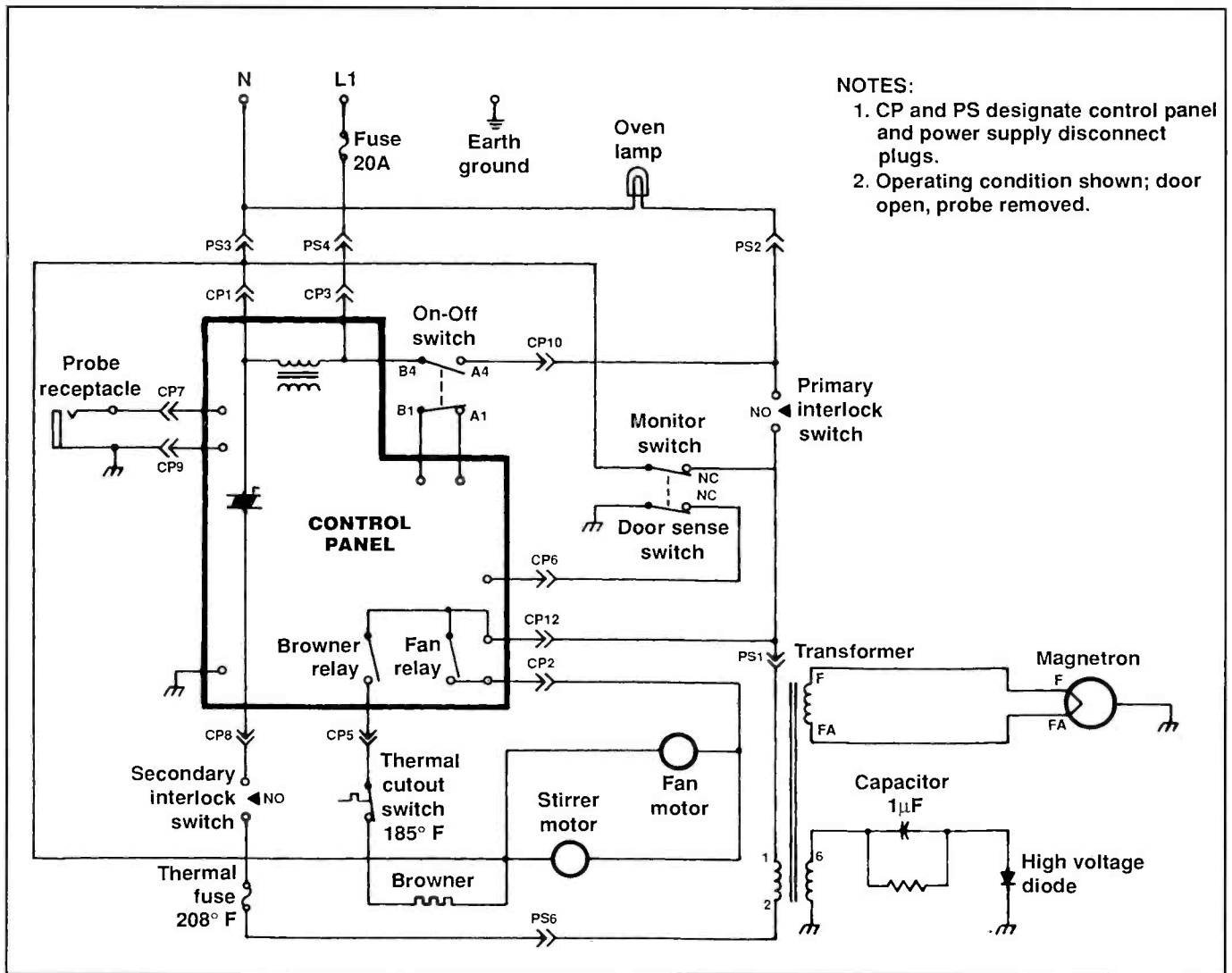

- NOTES:**
1. CP and PS designate control panel and power supply disconnect plugs.
  2. Operating condition shown; door open, probe removed.

**Figure 5.** The schematic diagram for the electrical circuit of the oven.

translate the voltage reading into an output in milliamperes. For example, if the meter indicates 3Vdc, the milliampere output is 300mA. A 3.25Vdc reading at this point provides 325mA of current. In equation form, the milliampere output is:

$$\text{mA} = V/\Omega \times 1000 (+/- 5\%)$$

The ohms portion of the equation relies on the value of the grounding resistor.

The non-operational portion of the magnetron test requires the use of an ohmmeter set to the low ohm range and a continuity check of the filament with the power disconnected. In addition, the test requires the disconnecting of the filament leads from the magnetron tube. Before attaching test probes or disconnecting the filament leads, carefully discharge the high voltage capacitor and the RF capacitors that connect to the magnetron tube.

The high voltage capacitor is at a high voltage potential and should be discharged either by placing a shielded jumper wire or an insulated screwdriver against the capacitor box and then to each capacitor terminal. Failure to properly discharge the capacitors allows a dangerous shock hazard to exist.

After disconnecting the power; discharging the capacitors; and disconnecting the leads from the magnetron, attach the ohmmeter leads to each magnetron terminal. The meter should show continuity. Then, attach one lead to a terminal and the other to the metal capacitor box. With the meter connected in this manner, the resistance reading should show infinity.

**Magnetron tube failure symptoms**

If the vacuum envelope of the tube is destroyed and air enters the magnetron,

internal arcing and high line current will occur. During operation, the tube will have a blue glow. In addition, the thermal fuse will open.

Normal usage can cause the magnetron filament to open. As shown in the last section, always perform an ohmmeter check on the tube filament connectors. Usually, the resistance will measure less than 1Ω. Low emission from the tube occurs when the tube current takes longer to reach the 300mA operating point. Without the proper amount of current, the tube will not oscillate at normal line voltages. With low emission, the milliampere test will show an output measurement of below 200mA. As a result, the oven will produce two-thirds or less power than normal into a load.

**Magnetron cooling assemblies**

When you look at the uncovered microwave oven from the top down, you

can often see a plastic plate that covers the magnetron cooling fan and oven light. The magnetron cooling fan cools the magnetron and forces air through the oven for venting. During operation, the fan draws air from the bottom of the oven and forces the air across the magnetron tube. Then, the air follows two paths and vents out the back of the oven and across the top of the cavity where it flows to the front of the cavity.

If the fan fails or if a fault within the magnetron causes the tube to overheat, a thermo fuse or thermal protector located near the tube will open. The thermo fuse is placed near or on the magnetron tube so that any temperature increase above 208F at the fuse mounting point will cause an open condition to occur. Some manufacturers may rely on thermal protectors placed at the magnetron and within the cavity rather than a single thermo fuse. The magnetron thermal protector will open at approximately 300F and reset at approximately 257F, while cavity thermal protector will open at approximately 243F and not reset.

#### Door switch assemblies

Although the number and type of switches contained within a microwave door assembly may vary, all provide the

same type of functionality. The oven used for this article uses four switches and includes plastic brackets that hold each switch to the front frame. Opening and closing the door activates the switches. In one scheme, the switch functions include primary interlock, secondary interlock, monitor, and sense (Figure 4A).

In another method for achieving the proper interlock sequence, the manufacturer encloses the door switches into a single module that controls all interlock, monitor, and logic functions (Figure 4B). This method simplifies the installation and the alignment of the door switches.

In the oven used here as an example, the primary interlock switch shown in the drawing is the lower switch in the assembly and closes the line side of the circuit. Figure 5 shows a schematic diagram for the electrical circuit of the oven. The secondary interlock switch opens and closes the neutral side of the circuit and fits at the top of the assembly.

A monitor switch causes the main power supply fuse to blow if the primary interlock switch remains closed with the oven door open. In effect, the monitor switch provides the safety function that prevents the operation of the oven and excessive microwave radiation leakage if the door assembly has a fault. The sense

## FREE CATALOG

1-800-338-0531

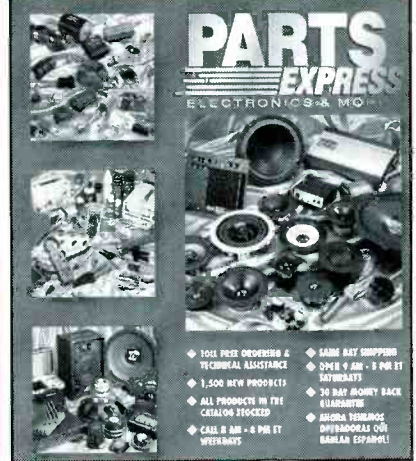

- ◆ Chemicals
- ◆ Test Equipment
- ◆ Wire/Cable
- ◆ Connectors
- ◆ Semiconductors
- ◆ Transformers
- ◆ Electronic Kits
- ◆ Books
- ◆ Amplifier Kits
- ◆ Project Boxes
- ◆ Loudspeaker Drivers
- ◆ Breadboarding Accessories

**CALL TOLL FREE:**  
**1-800-338-0531**

725 Pleasant Valley Dr., Springboro, OH 45066-1158  
Phone: 513-743-3000 FAX: 513-743-1677  
E-Mail: sales@parts-express.com  
Web Site: www.parts-express.com

Source Code:  
ESM

Circle (68) on Reply Card

### Chart Two — Microwave Oven Problem Symptoms and Possible Causes

#### Problem Symptoms

Oven Light and dial light operate, blower and time do not

Oven light, dial light and blower operate but timer does not

Oven light, power relay, dial timer, and blower motor operate. Oven does not cook or magnetron filament does not operate

All components operate but oven does not cook and magnetron does not glow

Open fuse primary circuit

Open transformer thermal fuse

Loud buzzing sound

Loud pulsing sound

#### Possible Causes

Top door interlock switch is not latching

Latch interlock switch is not functioning

No voltage at filament terminals of transformer

Open winding on filament transformer or open magnetron filament

Secondary interlock and/or sensing switch out-of-sequence. Defective secondary interlock or sensing switch.

Defective RF capacitors or defective magnetron. Magnetron may show a blue violet glow when the thermal fuse is replaced. Defective rectifier. Defective high voltage capacitor.

Defective power transformer

Stirrer blade deformed. Stirrer blade is not turning.

switch prevents the control board from counting down with an open door.

Testing of the door switches involves the basic use of an ohmmeter. With the power disconnected from the oven, set the ohmmeter range to R x 1 and check the continuity at each switch. With the example oven, the primary and secondary interlock switches should read zero with the door closed and infinity with the door open. Conversely, the monitor and sense switches should read infinity with the door closed and zero with the door open.

### Electronic control panels

The control panel used in the sample oven contains a printed circuit board, a touch pad, triac, a browner relay, fan relay, and an on/off switch. Most manufacturers consider the components found on the control panel as one unit and require the replacement of the entire assembly if one portion fails. Figure 6 shows the integration of a typical circuit panel/touch panel assembly.

To test the touch panel operation, disconnect the interface cable from the circuit board. Then, use an ohmmeter set to the R x 1 scale to check between the cable connectors. The resistance between the connectors should stay above 1 M $\Omega$  until a touch panel pad is depressed. With the pressing of the appropriate touch panel pad, the resistance between the connectors will drop to less than 100 $\Omega$ . In some cases where the manufacturer uses a ribbon-type interface cable, the very careful cleaning of the ribbon connector ends may restore the normal operation of the touch panel. Chart 1 provides a sample diagnostic flow chart for electronic control circuit board problems and solutions, while Chart 2 shows a sample of a manufacturer's diagnostic test chart for the interface cable connectors.

### Power supplies

Microwave oven power supplies contain the following key components:

- A line fuse;
- A low voltage transformer;
- A high voltage transformer;
- A high voltage capacitor; and
- A high voltage diode.

While the line fuse protects house wiring in the event of a short within the oven, the low voltage transformer provides voltages for the electronic control panel. The high voltage transformer pro-

duces the high voltage and filament voltage for the magnetron tube operation. Figure 7 shows a typical microwave oven power supply assembly.

Applying 120Vac to the primary terminals of the power transformer allows 2000Vac to develop across the high voltage winding terminal and ground and 3.15Vac across two other terminals in the secondary. When checking the high voltage transformer, *never attempt to measure the high ac voltage that develops across the high voltage winding.* Instead, with the power disconnected and the high voltage capacitor discharged, use an ohmmeter to measure the resistance between the high voltage terminal and ground. A good transformer will show approximately 68 $\Omega$  at this check point. To check the filament voltage, disconnect the high voltage lead and then measure the ac voltage across the filament terminals of the transformer. The measurement should show approximately 3.15Vac.

The 1.0 $\mu$ F, 4.5kV, high voltage capacitor combines with the magnetron and the high voltage diode to form a voltage doubler circuit. Checking the high voltage capacitor involves removing the wiring from the capacitor and then discharging the capacitor. With the capacitor safely discharged, use an ohmmeter set to the highest scale to measure the resistance across the capacitor terminals. A good capacitor should cause the meter reading to move toward infinity

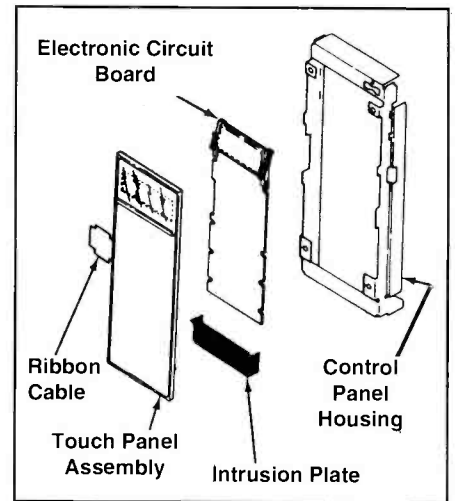

Figure 6. A microwave oven control Circuit/Touch Panel Assembly

as it charges. Checking for a short between the plates and the case again requires that the ohmmeter be set to the highest reading. Measurements between the terminals and the case should show infinity at all times.

The high voltage diode connects in parallel between the transformer and the capacitor. When the end that connects to the transformer is negative with respect to ground, the diode conducts and charges the capacitor. When the same end is positive with respect to ground, the magnetron tube will conduct. Testing for the high voltage diode follows the same routine used for checking other semiconductor diodes with an ohmmeter. ■

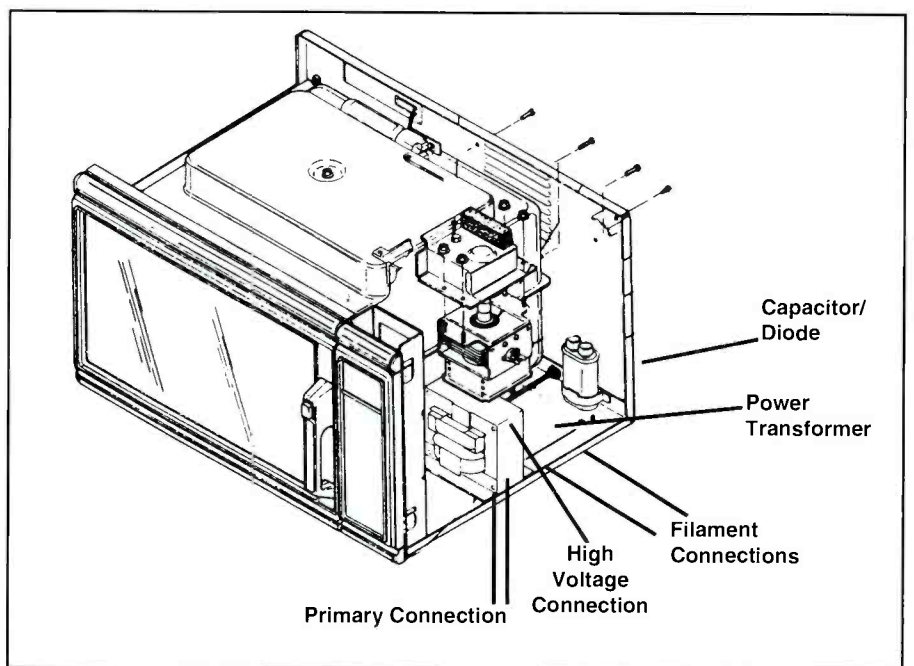

Figure 7. Power supply assembly

# Test Your Electronics Knowledge

by J. A. Sam Wilson

This TYEK is for entry-level technicians. Super techs will get a score of 100% correct!!

1. By combining resistors in series and parallel, can you calculate the resistance across terminals A and B for the circuit in **Figure 1**?

2. How many kHz are there in 25MHz?

3. Can you adjust the frequency of the circuit in **Figure 2** by varying the resistance of  $R_2$ ?

4. What is the next binary count in the following series? 11110, 11111, ...

5. Phrone Smedge measures the resistance of a thermistor using a Simpson 260 Analog multimeter. He determines the resistance to be  $4577\Omega$ . Then, he connects the thermistor across a 1.5V cell and, by

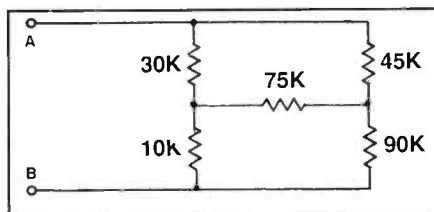

**Figure 1.** Can you calculate the resistance across A and B?

Ohm's law, calculates the current to be:

$$I = V/R = 1.5/4577 = 327.726\mu.$$

What is Phrone's biggest mistake?

6. Divide 376 by  $1/6$ .

Answer \_\_\_\_\_

7. How is it possible to cool a very large triode in a transmitter by circulating water along the plates? Shouldn't the water short-circuit the plate circuit?

8. Is the following statement correct? One of the 2 wires used to deliver 60Hz AC power to your house is grounded.

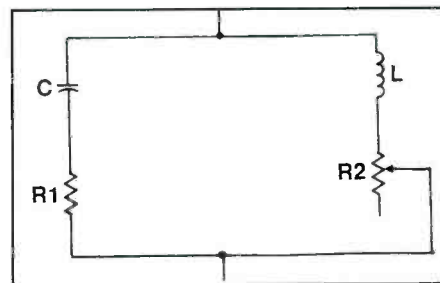

**Figure 2.** Can you adjust the frequency of this circuit by varying the resistance of  $R_2$ ?

9. A loading coil at the bottom of a whip antenna used for an amateur radio transmitter is used to make the antenna:

- A. appear to be longer than it actually is.
- B. appear to be shorter than it really is.

10. If you cut a  $300\Omega$ , 5-ft. length of parallel-wire transmission line in half, you will have two 2.5 ft. lengths of  $300\Omega$  transmission lines. Right?

Wilson is the electronics theory consultant for ES&T.

(Answers on page 59)

Call today for your **FREE** catalog!

# B&D Enterprises

PO BOX 460 • MAIN & LIBERTY RUSSELL, PA 16345

FACTORY AUTHORIZED SEMICONDUCTOR DISTRIBUTION FOR:

SANYO
NEC
Sanken
Shindengen

(AND MANY OTHERS!)

REDUCED PRICES ON 1000'S OF ITEMS

ORDER TOLL FREE!

1-888-815-0508

TECH SUPPORT 814-757-8300

FAX 814-757-5400

BUSINESS HOURS: 8:00 AM - 7:00 PM EST

Visit our Web Site at [www.bdent.com](http://www.bdent.com)

MINIMUM ORDER ONLY \$15.00

C.O.D. ACCEPTED

(Cash or Company Checks Only)

MEMBER

SAME DAY SHIPPING

(on orders placed before 4:00 PM EST)

# Switched-mode power supplies

by John A. Ross

All modern televisions, monitors, personal computers, VCRs, and many other types of electronic equipment rely on a different type of power supply, called *the switched-mode power supply* (SMPS). Switched-mode power supplies offer advantages such as reduced size, weight, and cost. The high-frequency operation of an SMPS allows the use of smaller and lighter components than those used in linear power supplies. In addition to those benefits, an SMPS is more efficient than a linear power supply. Because an SMPS operates either fully on or fully off, this type of power supply loses little power and has an efficiency in the range of 85%.

## SMPS basics

Linear power supplies have a line input voltage traveling into a power trans-

former and then through a rectifier circuit, filter, and regulator circuit. With switched-mode power supplies, the concept changes slightly. Rather than begin with a transformer, the SMPS begins with a full-wave rectifier circuit connected directly to the line and then progresses to a high-frequency transformer, a power transistor, and a pulse generator. Figure 1 shows a block diagram for a typical switched-mode power supply. The SMPS supplies 132Vdc for the sweep circuits, 12Vdc for a remote control preamplifier, 12Vdc for the turn-on, and 35Vdc for the audio stages of a television receiver.

## SMPS components

As with the linear power supplies, switched-mode power supplies contain a mix of passive and active components. Those include bipolar junction transistors, rectifiers, silicon-control rectifiers, shunt regulator ICs, opto-isolators, filter and bypass capacitors, resistors, metal

oxide resistors, and thermistors. Each individual component type affects the performance of the switching power supply and involves tasks such as feedback, control, rectification, overvoltage and overcurrent protection, regulation, isolation, filtering, and voltage division.

When studying the operation of an SMPS, it makes it easier to understand the operation of the circuits if you consider the components by function. For example, filter capacitors either filter the rectified, and sometimes doubled, ac line input voltage or filter the output voltages from the SMPS. Other types of capacitors in the circuit provide bypass paths. SMPS also contain a combination of general type resistors and flameproof resistors, *metal-oxide varistors* (MOVs), and thermistors. While the general type resistors are often found in voltage divider circuits, the flameproof resistors are found in the return circuit for the switching regulator or in the ac line circuit. MOVs and ther-

Ross is a technical writer and microcomputer consultant for Ft. Hays State University in Hays, KS.

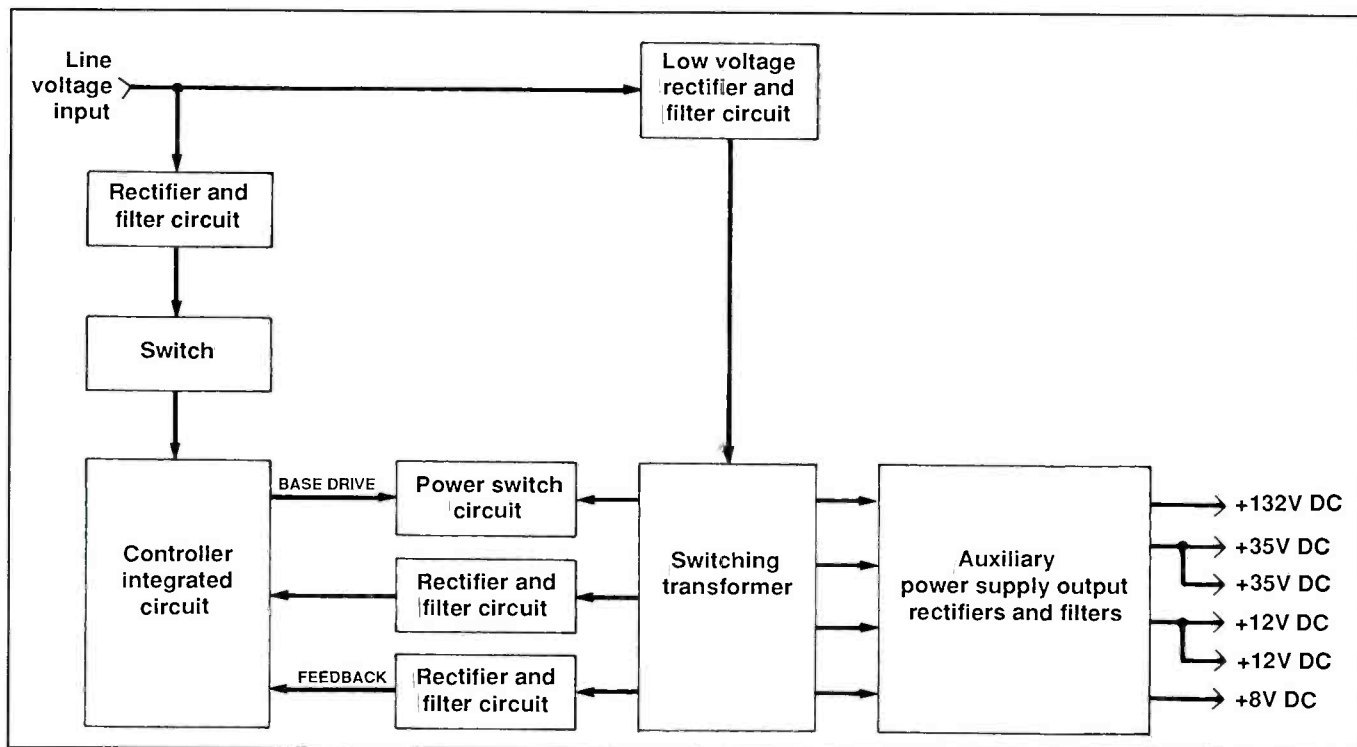
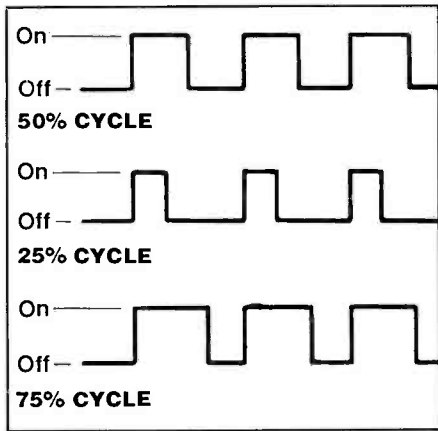

Figure 1. This is the block diagram for a typical switch-mode power supply. This SMPS supplies 132Vdc for the sweep circuits, 12Vdc for a remote control preamplifier, 12Vdc for the turn-on, and 35Vdc for the audio stages of a television receiver.





**Figure 2.** In pulse-width modulation, energy is stored in a magnetic field during the on cycles of the pulse train. During the off cycles, the stored energy provides output power and compensates for any changes in the line voltage or the load.

mistors provide protection against severe surges and appear in the ac line circuits while opto-isolators or opto-couplers establish isolation.

Active components, such as bipolar transistors, MOSFETs, and SCRs, may operate as part of a feedback circuit, as regulators, or in overvoltage and overcurrent protection circuits. Bipolar junction transistors either work as components in a feedback circuit or function as the SMPS switching device. The type of transistor used in the particular circuit varies with the function. For example, a

power transistor capable of handling high voltages will work as a switching device.

In addition to transistors, MOSFETs and SCRs may appear in the switching role. SCRs are also found in overvoltage and overcurrent protection circuits. Rectification occurs through the use of either discrete or packaged diodes. Most SMPS units use diodes for ac line rectification or in voltage doubler circuits. The switched power supplies usually rely on some type of 3-pin IC regulator for regulation of the output voltages.

### SMPS operation

All switched-mode power supplies use a high frequency switching device, such as a transistor, MOSFET, IGBT, SCR, or triac, to convert the directly rectified line voltage into a pulsed waveform. An SMPS that has a lower power requirement will feature a conventional transistor or MOSFET as a switcher while high power SMPS units will rely on an IGBT, SCR, or triac. Each of the last three components offers latching in the *on* state and high power capability. However, this type of capability also requires more complex circuitry to ensure that the semiconductors turn off at the correct time.

The switching on and off of the transistor closes and opens a path for dc current to flow into the transformer. The changing current into the transformer pri-

mary winding produces a changing magnetic field around the winding. The transformer is so constructed that this changing magnetic field is magnetically coupled to the transformer secondary winding. As a result, voltage is induced in the secondary winding. Rectifiers and filters in the secondary circuit rectify and filter into stable supply voltages.

### SMPS input

After the rectification of the line voltage, the SMPS may have two possible dc inputs. With the first, 150Vdc to 160Vdc arrives at the SMPS after the direct rectification of 115Vac to 130Vac line voltage. However, some SMPS units require a higher input voltage. In this case, a voltage doubler supplies 300Vdc to 320Vdc to the SMPS input. Other power supply designs rectify a 220Vac to 240Vac line voltage and also supply the 300Vdc to 320Vdc to the SMPS input.

While rectification of the line voltage occurs through the use of a full-wave bridge rectifier or a voltage doubler, the input to the SMPS also includes inductors and capacitors for the purpose of filtering line noise and any voltage spikes. Those components also eliminate the transmission of any radio frequency interference generated by the power supply back into the ac line. As mentioned, most designs feature metal-oxide varistors across the

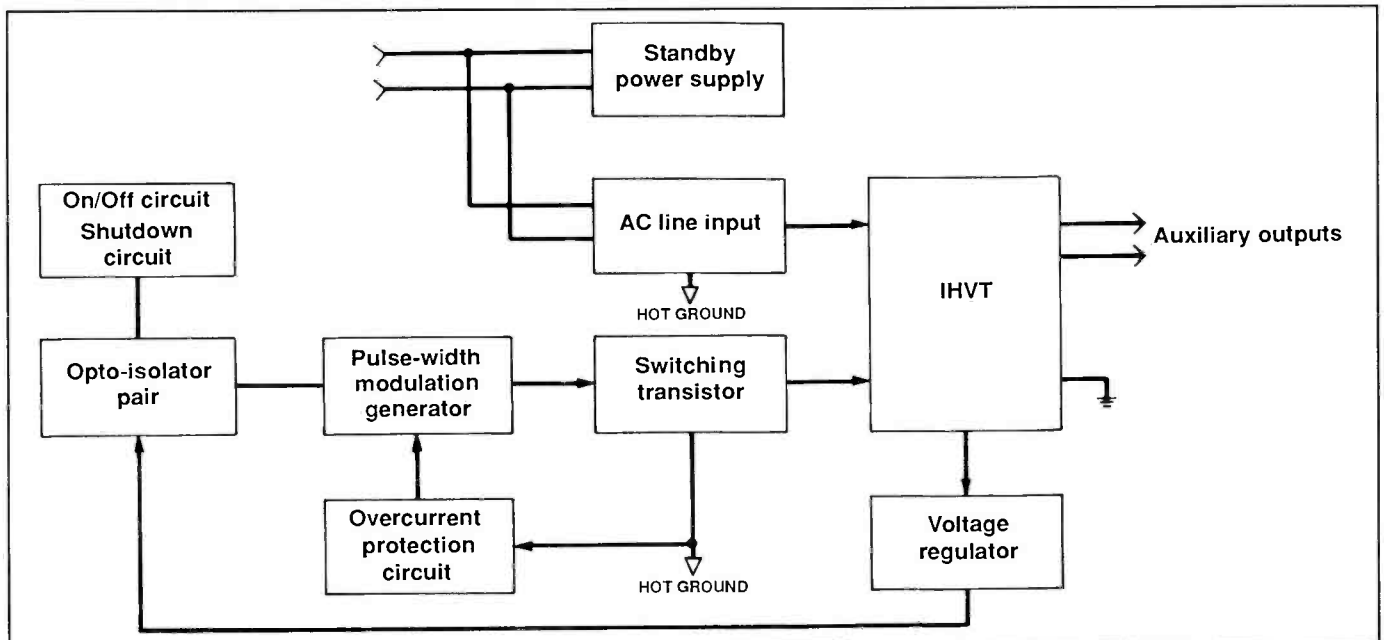

**Figure 3.** Scan-derived power supplies operate at the horizontal oscillator frequency of 15,750Hz and supply high voltages and currents. The supply potential for the scan-derived power supply is taken from a portion of the horizontal output voltage in the form of voltage pulses.

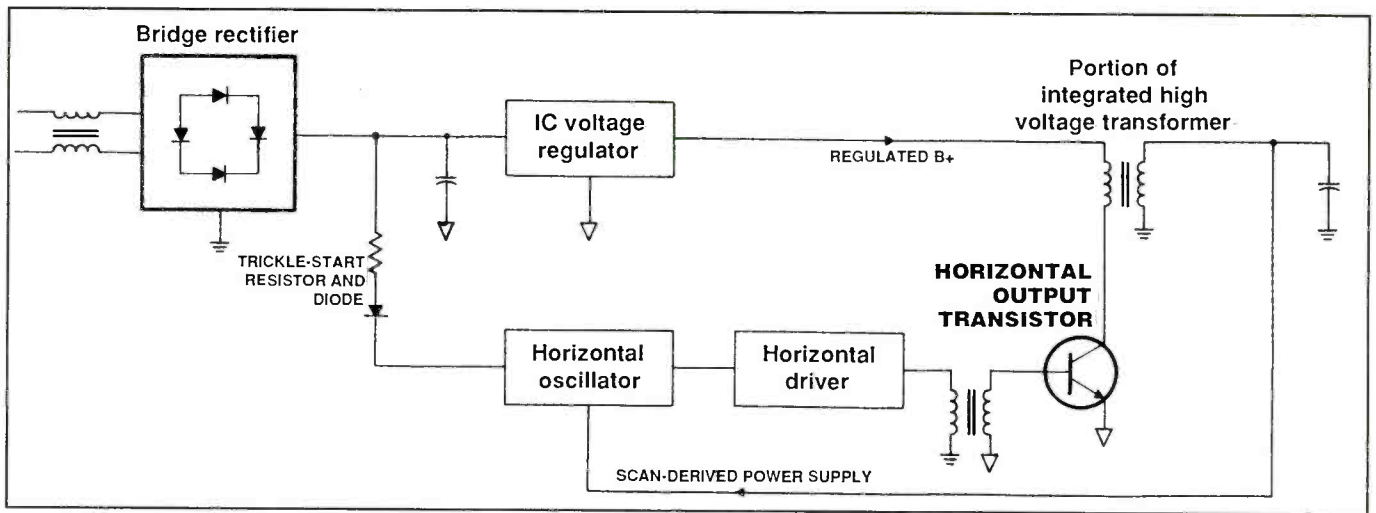

Figure 4. The trickle-start system shown here is one method for starting the oscillator in a scan-derived power supply.

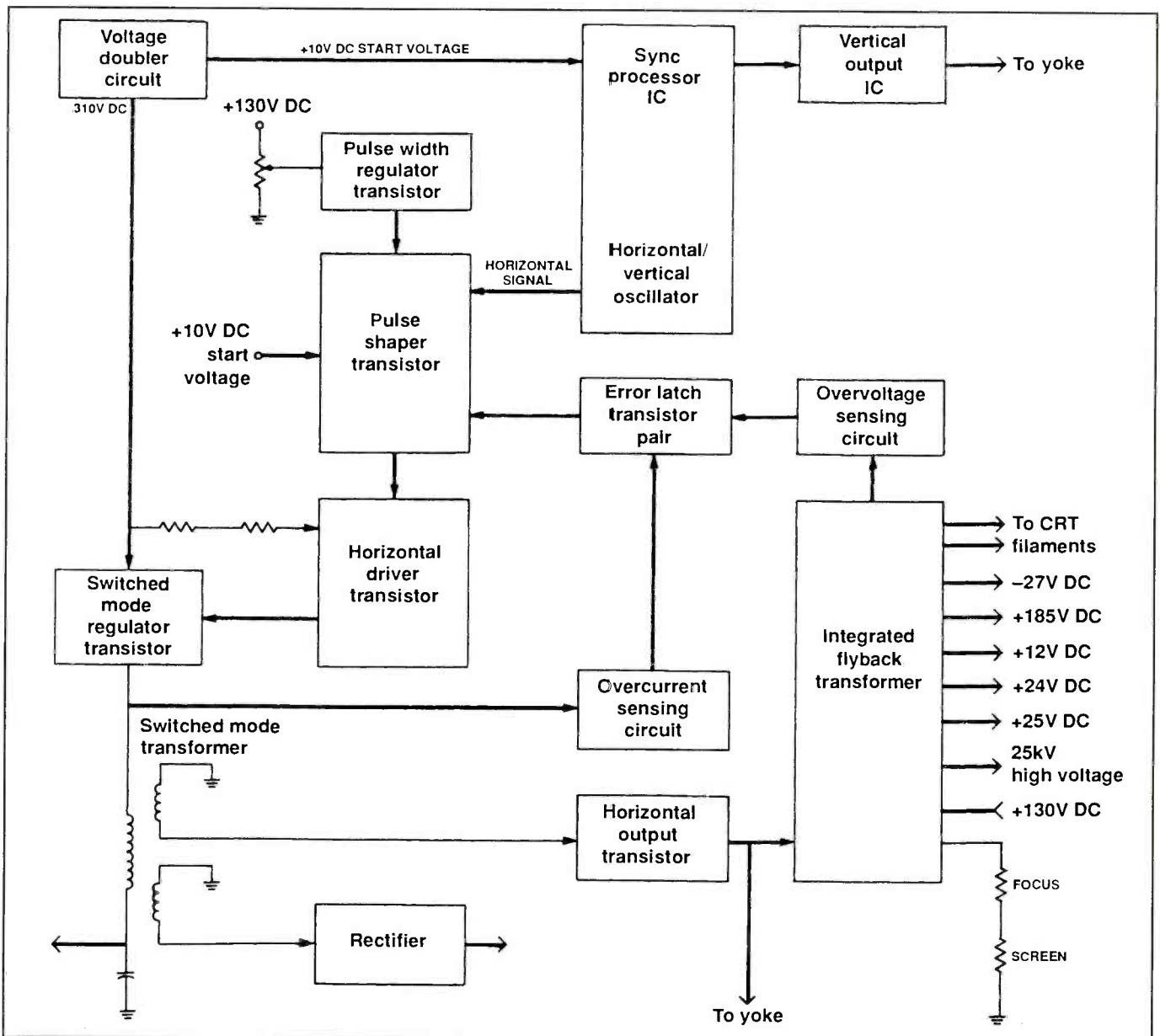
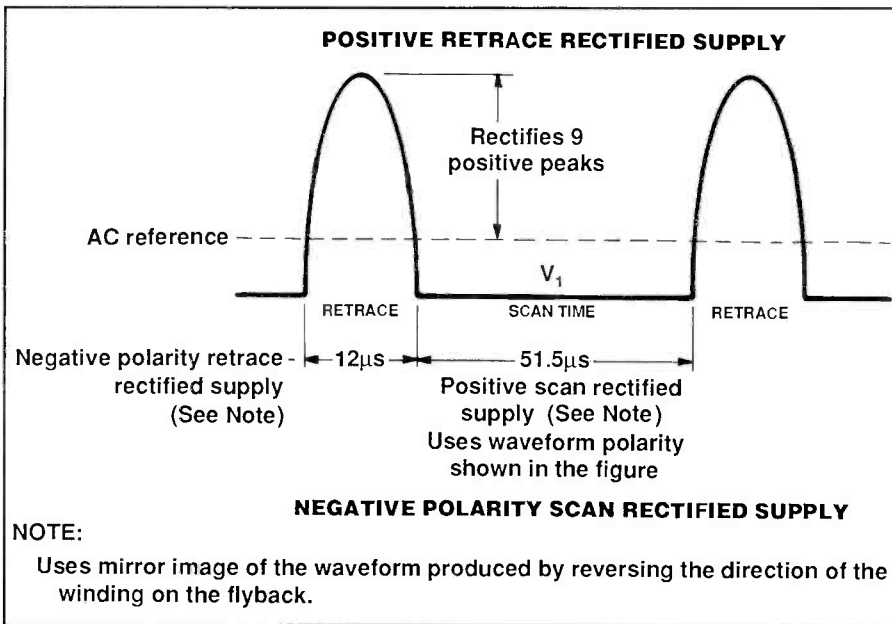

Figure 5. This block diagram of a color television power supply system illustrates how a system operating at the horizontal sweep frequency can establish the low and high voltages needed for the entire receiver, the tuner and tuner control system, I-F signal processing systems, video and chrominance processing systems, audio systems, vertical deflection systems, the CRT anode and focus voltages, and the CRT screen, or G2, control.



**Figure 6.** Scan-derived voltage supplies utilize the waveform shown in Figure 6 to produce: a positive-retrace rectified supply, a positive-scan rectified supply, a negative-polarity-retrace rectified supply, and a negative polarity scan rectified supply. The figure shows which points of the waveform correspond with the four power supply types.

input lines for additional protection against surges.

### Switched-mode regulators

Switched-mode regulator circuits provide the advantage of having a control device that has minimal power dissipation for the entire duty cycle. In particular, these circuits provide:

- The capability of producing an output voltage higher than the input voltage;
- The capability of producing either a positive or negative output voltage from a positive input voltage; and
- The capability of producing an output voltage from a dc input voltage.

A switched-mode regulator circuit uses a control device, such as a bipolar transistor, a field-effect transistor, or a silicon-controlled rectifier, to switch the supply power in and out of the circuit and regulate the voltage. Switching occurs because of the ability to send the device into either

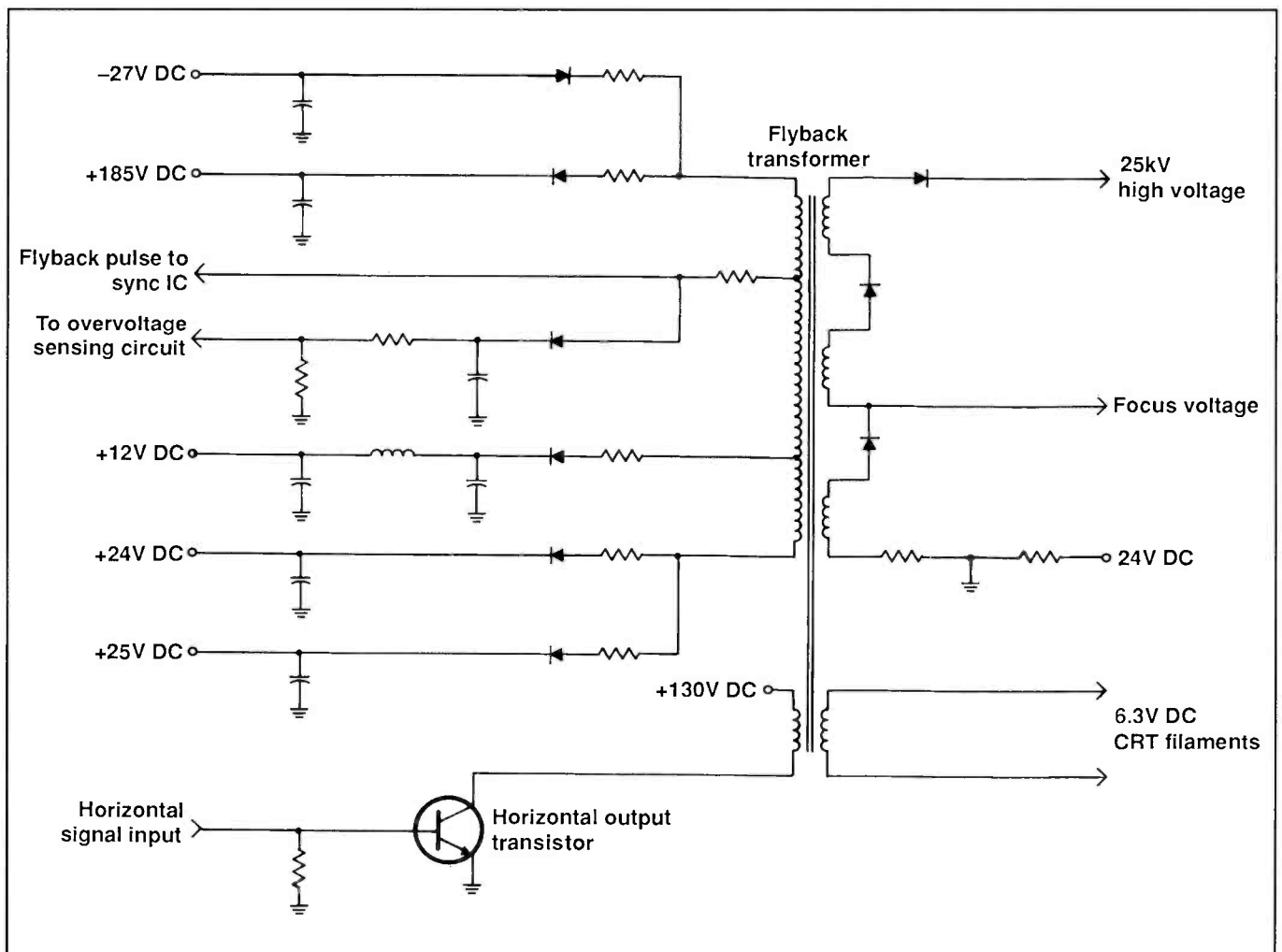

**Figure 7.** In this schematic drawing of a sample auxiliary power supply circuit, the +12Vdc, +24Vdc, +25Vdc, and -27Vdc supplies are scan-rectified while the +185Vdc, the overvoltage sensing voltage, the focus voltage, and the 25kV CRT anode voltage are retrace-rectified voltages.

saturation, the completely-on state, or into cut-off, the completely-off state.

The duty cycle of the device, or the ratio of "on" time to "off" time, establishes the regulation of the output voltage level. Therefore, regulation in a switched-mode power supply occurs through the pulse-width modulation or the pulse-rate modulation of the dc voltage. *Pulse-width modulation* varies the duty cycle of the dc voltage while *pulse-rate modulation* varies the frequency of the dc pulses.

Figure 2 provides an illustration of pulse-width modulation. In the figure, the on-cycles of the pulse train energy double as the time periods for storing energy in a magnetic field. During the off cycles of the pulse train, the stored energy provides output power and compensates for any changes in the line voltage or the load. The pulse-width modulation of the switching transistor changes the conduction time of the device by varying the pulse frequency.

When the supply is lightly loaded and the line voltage is within tolerance, the switched-mode power supply switches the power into the power supply for only a short period of time during each cycle. Either a heavy load, a low line voltage, or a combination of both conditions will cause the switched-mode power supply to transfer more energy over a longer period of time into the power supply. As a result, the switching frequency varies from a higher frequency for lower loads to a lower frequency for higher loads.

### SMPS transformer operation

Switched-mode power supplies do not include any type of conventional power transformer and, as a result, do not have line isolation. At the input of the power supply, a small, high frequency transformer converts the pulsed waveform taken from the switching device into one or more output voltages. Other components following the high frequency transformer rectify and filter the voltages for use by signal circuits.

### Isolation in the SMPS system

Although the SMPS does not provide line isolation, the use of the high frequency transformer establishes an isolation barrier and the type of characteristics needed to operate in the flyback mode. An *opto-isolator* or *opto-coupler* is a combi-

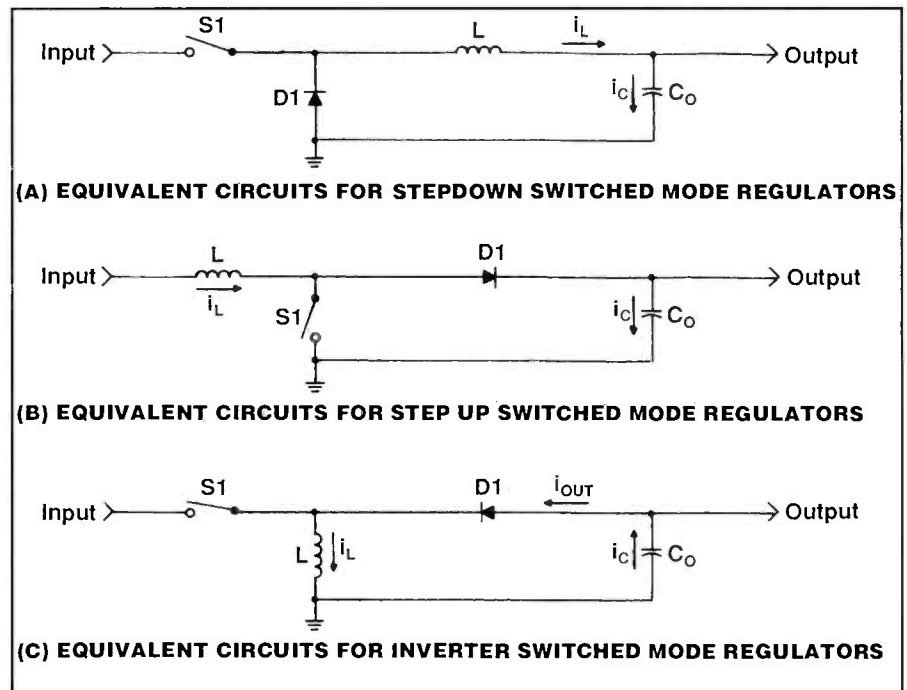

Figures 8. A, B, and C illustrate the operation of a step-down switched-mode regulator, a step-up switched-mode regulator, and an inverting switched-mode regulator through equivalent circuits.

nation of an LED and a photodiode in one package and establishes an isolation barrier between low voltage secondary outputs and the ac line. Depending on the circuit configuration, a small pulse transformer or an opto-isolator sets up feedback across the isolation barrier. The feedback from the opto-isolator controls the pulse width of the switching device and maintains regulation for the primary output of the SMPS.

Most small switched-mode power supplies, such as those used for VCRs, use opto-isolators for feedback. Whenever a primary output voltage reaches a specified value, a reference circuit in the output turns on the LED. In turn, the photodiode detects the light from the LED and reduces the pulse width of the switching waveform. This establishes the correct amount of output power and maintains a constant output voltage. Along with the primary output winding, the transformer has six or more separate windings that provide positive and negative voltages for the system.

### Scan-derived power supplies

The first portion of this article describes the fundamental theories used for switched-mode power supplies and the components commonly seen within the SMPS circuits. Those descriptions

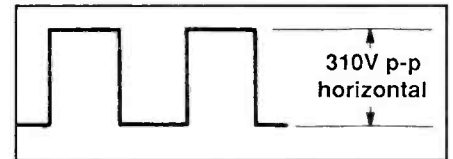

Figure 9. When checking the operating performance of the switching device in a SMPS, use the oscilloscope to evaluate the waveform at the base and collector of a switching transistor or the drain of a MOSFET. The measured waveform should resemble the waveform shown in Figure 9.

can be applied to switched-mode power supplies found in a large number of electronic devices. This basic SMPS design supplies low voltages for the device and operates at lower frequencies.

*Scan-derived power supplies* described in this and the following sections are derivatives of the basic SMPS design. The key differences found with scan-derived power supplies are the application, the operating frequencies, and the method of providing a supply potential. Used specifically in television receivers and shown in the block diagram of Figure 3, scan-derived power supplies operate at the horizontal oscillator frequency of 15,750Hz and supply much higher voltages and currents. The input supply potential for the scan-derived power supply is taken from a portion of the hori-

### Service Call: Sylvania model RAJ147 television with no sound and no raster

When the Sylvania model RAJ147 color television came into the service center, the technician found that the receiver had no raster and no sound. Before checking any part of the receiver, the technician took time to study the type of power supply used in the receiver. Referring to the schematic diagram for the chassis, the technician found that transistor Q401 switches the primary of chopper transformer and should have a +163Vdc at the collector. In addition, the technician found that diodes D416, D417, D418, and D419 supplied voltages to the secondary sources. Figure 12 shows a section of the scan-derived power supply.

Component checks showed that Q401 had shorted and that resistor R401 and fuse F400 had opened. After replacing the defective parts, the technician used a variable isolation transformer to lower the ac line voltage to 45Vac. Voltage checks showed that +62Vdc at the Q401 collector (normal under the ac line conditions) and +67Vdc at the cathode of D416. However, a check of the schematic showed that the D416 cathode should have only +11.2Vdc. While the voltages at the other diodes were closer to normal, all measured high. Increasing the line voltage to 68Vac caused the voltage at the diodes to decrease back to normal. At this point, a check of the higher flyback secondary voltages also showed normal readings. However, increasing the line voltage to 90Vac again caused Q401 to short, and resistor 401 and fuse F400 to open. To check for a possible intermittent short in the secondary voltage supplies, the technician disconnected one end of R505, D420, R418, R425, R417, and D480 to remove the loads from the chopper transformer. In addition, the technician also disconnected one end of R415 to isolate the error latch transistors from the chopper transformer. Still, no problems surfaced.

Further checks took the technician to the Q400, the pulse width regulator. While in-circuit tests disclosed no problems, an out-of-circuit check of the transistor with a transistor tester showed that a leaky condition existed. Replacement of the pulse width regulator transistor, the chopper transformer driver transistor, the open R401, and the blown fuse returned the television to normal operating conditions.

power supply closely, we find that it contains the SMPS circuits found in the prior sections. In television systems, the use of a scan-derived power supply increases efficiency and cuts power consumption because of the capability to supply higher current loads.

A scan-derived power supply features four basic blocks. Those are:

- The rectification of the ac line voltage and the conversion of the rectified line voltage into an unregulated power supply;
- The feeding of the unregulated power source into a dc regulator;
- The use of a start-up supply circuit to supply voltage for the receiver horizontal oscillator;
- The use of a high voltage transformer, or flyback, to supply the high voltages needed for the receiver CRT and the low voltages for the receiver circuits.

While we have become familiar with the first two blocks of the scan-derived power supply when studying SMPS basics, the second two blocks offer several new twists.

#### Providing a start-up voltage

Taking advantage of the excess energy from the horizontal scan section eliminates the need for both a low voltage power transformer and anything more than a basic low voltage rectifier circuit. The output circuits in a television cannot operate unless properly driven by the horizontal oscillator. This becomes more complicated when we find that the voltages needed for the operation of the oscillator come from the output stage.

zontal output voltage in the form of voltage pulses.

#### Deriving pulses from scan circuits

Because the horizontal scan section of a television receiver provides the pulses,

the circuit is called a scan-derived power supply. The use of scan voltages depends on an energized horizontal oscillator which provides the drive voltage for the horizontal output circuits. However, if we examine the design and operation of the

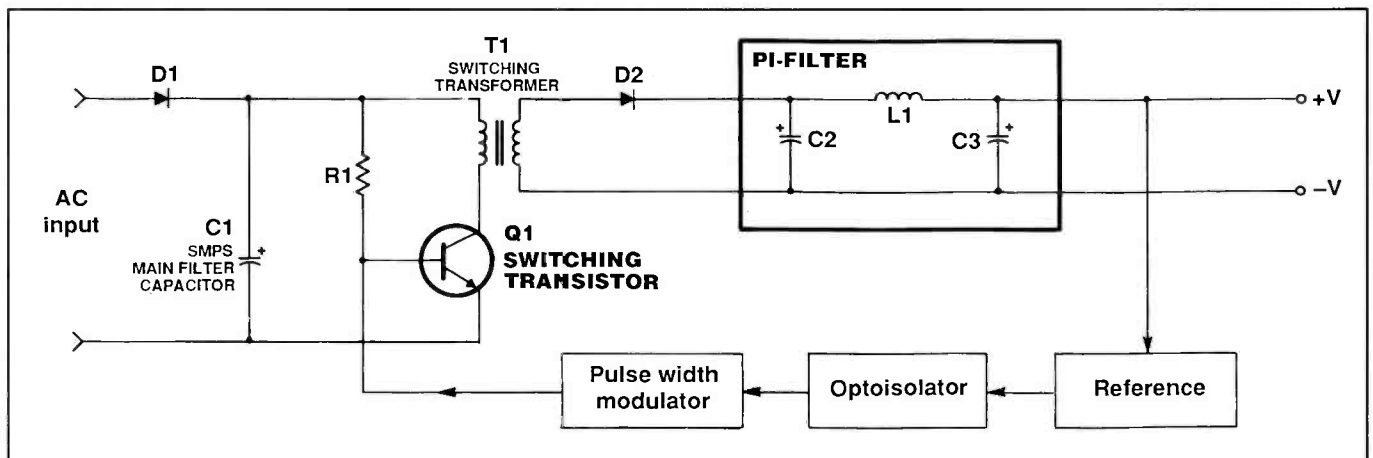

**Figure 10.** This is a pi filter normally found on the auxiliary power supply lines of an SMPS. When the capacitor on the input side of the filter fails, the inductor absorbs most of the switching voltage from the transformer and the rectifier diodes. As a result, the regulator transistor works harder to generate the +5Vdc desired at the output. With this additional load on the power supply, other capacitors in the supply begin to open.

### Service Call: Samsung model TXB1940 television in shut-down mode

When the customer returned the Samsung television to the service center, the receiver would not power up. By paying close attention, though, the technician could hear the tic-tic-tic sound that indicated a problem with the switched-mode power supply. When checking voltages, she found a very high B+ voltage of +157.2Vdc at the horizontal output transistor collector but zero volts at the transistor base and no voltage at the horizontal output transistor side that connected to the transistor base.

At first, the technician concluded that the receiver had gone into shutdown because of the excessive voltage at the horizontal output transistor collector. However, a further check at the horizontal oscillator IC showed that incorrect voltages existed at pin 33 of the IC. The voltage at this particular pin is supplied by a regulator transistor. Instead of having the necessary +8Vdc so that the oscillator could maintain its correct frequency, the voltage check at pin 33 showed +2.8Vdc.

Rather than jump to conclusions about a defective regulator or oscillator, the technician began checking a voltage divider circuit connected to the regulator. By performing several out-of-circuit resistance checks on resistors in the voltage divider, she found that the value of a 39 $\Omega$  resistor had increased to 130 $\Omega$  and had reduced the line voltage input into the regulator. The replacement of the resistor restored the receiver to its normal operating condition.

To counter this situation, manufacturers include a start-up voltage circuit as part of the scan-derived power supply. The *start-up power supply* supplies a small amount of voltage or current to the horizontal oscillator so that the oscillator can energize and drive the output stage. The start-up voltage or current stops once the horizontal output stage begins to operate. Regardless of whether the start-up circuit relies on a kick-start or a trickle-start, the design has the same purpose.

#### Kick-start circuits

A *kick-start circuit* supplies a small amount of voltage to the horizontal oscillator after the turning-on of the receiver. This type of circuit includes a start transformer and a large capacitor and has the secondary of the transformer connected in series with the capacitor. After the receiver is initialized, the charging pulses from the capacitor energize the windings of the transformer. In turn, the transformer delivers a start-up voltage to the horizontal oscillator and driver circuit.

#### Multivibrator start-up system

Another type of kick-start system relies on a multivibrator rather than the combination of a start-up transformer, rectifier diodes, and filtering to produce the necessary start-up voltages. The *astable multivibrator start-up system* kick-starts the horizontal output transistor and the sweep

circuit directly from the 150Vdc supply.

The power supply develops at the turn-on of the television receiver and causes the multivibrator to oscillate at that point. During operation, the output voltage at the collector of one transistor found in the multivibrator is a square wave with a value oscillating between the B+ voltage value and ground. The frequency of the oscillation varies with the ac line voltage and — with a normal line voltage — has a value between 10KHz and 20KHz while the square wave has a duty cycle of 70% on and 30% off.

The output current flows through an added winding on the horizontal driver transformer of the television receiver. As the square wave current oscillates and flows through the winding, it also flows into the horizontal output transistor and causes the transistor to conduct. Once the transistor begins to conduct, the sweep circuit starts and develops the operating voltages for the receiver. After the development of the operating voltages, the start-up circuit turns off through the stopping of the multivibrator oscillation. When that happens, current through the start-up winding of the driver transformer ceases to flow.

#### Trickle-start circuits

The *trickle-start system* shown in Figure 4 uses a slightly different method for starting the oscillator. With this method, a large resistor connects in series

with either a diode or regulator transistor and in between the unregulated positive voltage obtained at the rectifier circuit and the horizontal oscillator. The value of the resistor is chosen so that it cannot supply enough current to operate the receiver. Instead, only enough current flows so that the oscillator is energized. Once the oscillator energizes and drives the output stage so that the output stage can supply dc power, the current ceases to flow through the resistor.

#### Integrated high voltage transformers

In a television receiver, the operation of the scan-derived power supply also depends on the use of an *integrated high voltage transformer* (IHVT). If we take the functions of the flyback transformer and the high voltage tripler and combine them into one package, we have the essential ingredients for an integrated high voltage transformer, or, as some manufacturers label the device, an integrated flyback transformer.

An integrated high voltage transformer segments the high voltage windings into several parallel-wound sections that series-connect with one another through diodes. One housing contains both the segments and the diodes. The pulse rectification provided by the IFT produces all the voltages needed by the chassis.

#### Auxiliary power supplies

Figure 5 uses a block diagram of a color television power supply system to illustrate how a system operating at the horizontal sweep frequency can establish the low and high voltages needed for the entire receiver. Looking at the drawing, the integrated flyback transformer is one part of the horizontal output switched-mode power supply. A 6.3Vac winding on the flyback transformer drives the CRT filament while a horizontal pulse from another winding on the flyback resets an SCR operating as a control device in another switched-mode power supply. Because the horizontal pulse forces the SCR anode to fall below the level of the cathode during retrace, the SCR resets every horizontal cycle. Turn-on of the SCR occurs during the next horizontal scan period.

All this leads to the generation of auxiliary voltage supplies for the:

- Tuner and tuner control system;
- I-F signal processing systems;

**Service Call: RCA CTC-136 chassis has  
only a tic-tic-tic sound at turn-on**

When the technician applied power to the RCA CTC-136 chassis, he heard a distinct tic-tic-tic sound and noticed that the tuner indicator LEDs would not illuminate. Additional checks showed that several voltages, such as the tuning voltage, were missing. Bypassing the start-up SCR in the SMPS allowed the receiver to have a normal raster. However, the RCA television would display only snow.

As the technician consulted the service literature and began static tests on the SMPS, he found that C422 had become leaky. After replacing the receiver load with a dummy load and replacing C422, the technician tested the SMPS by using a variac to slowly bring the line voltage to the 70% and then 100% levels. The SMPS maintained regulation. Replacement of the capacitor restored the receiver to its normal operation. Post-repair checks of the power supply voltages and the tuner voltages showed that all voltages were within normal tolerances.

- Video and chrominance processing systems;
- Audio systems;
- Vertical deflection systems;
- The CRT anode and focus voltages;
- The CRT screen, or G2, control.

Certainly, each type of system requires a slightly different power supply. To accommodate these differences, scan-derived systems utilize transformer winding and grounding schemes to establish different supply voltages. The voltage supplies utilize the waveform shown in Figure 6 to produce:

- A positive-retrace rectified supply;
- A positive-scan rectified supply;
- A negative-retrace rectified supply;
- A negative scan rectified supply.

The figure shows which points of the waveform correspond with the four power supply types.

The positive-retrace rectified supply rectifies a large portion of the waveform to yield a high voltage with low-current loading used to supply dc voltages for the video and chroma output circuits. Reversing the direction of the flyback winding produces a mirror image of the waveform shown in Figure 6 and the lower-voltage, higher-current supply needed for the vertical output circuits, I-F signal processing circuits, and audio circuits. While the negative-polarity-retrace rectified supply continues to utilize a reversed flyback winding, it rectifies negative-going retrace pulses and produces the negative-polarity high voltage with low current loading needed by tuner and tuner control systems. The negative-polarity-scan rectified supply generates low voltages with a higher current drain.

Looking at Figure 7, the +12Vdc, +24Vdc, +25Vdc, and -27Vdc supplies are scan-rectified while the +185Vdc, the overvoltage sensing voltage, the focus voltage, and the 25kV CRT anode voltage are retrace-rectified voltages. The two types of scan-rectified supplies operate at a duty cycle of approximately 80 percent and produce higher current loads. Because of this, diodes used in the scan-rectified supplies must be able to block reverse voltages that have nine-to-ten times the amplitude of the output voltage.

**Service Call — TTX-3700 17-inch computer monitor with shorted rectifier**

At first glance, the 17-inch SVGA computer monitor seemed to work fine. However, the technician found that a rectifier in the 185Vdc line would become short-circuited if the monitor was turned on less than 30 seconds after being turned off. A period of more than 30 seconds between turn-off and turn-on allowed the monitor to operate normally.

The technician suspected that an excessive peak current at the filter capacitor in the SMPS was responsible for the shorted rectifier. To verify his suspicion, he checked to see if the 185Vdc was directly derived from the ac line input and if the monitor contained an IC for the control of the pulse-width modulation. Both checks proved his suspicions correct.

Although he had initially decided to replace the PWM controller, the technician decided to take another look at the current limiting circuit and the type of diode used in the rectifier circuit. This particular circuit placed the degaussing coil in series with the ac line input and used the coil as a current limiting device. The coil contained an MOV(Metal-oxide Varistor) for surge protection. When replacing the diode, the technician also verified that he was using a diode rated for switched-mode operation rather than a common rectifier.

As a result of his checks, the technician replaced the diode with the correct type of rectifier and replaced the MOV in the degaussing circuit. The degradation of the MOV in the degaussing coil had altered the time constant of the current limiting circuit. The original installation of an incorrect diode type had placed the diode under stress when the time constant changed and eventually caused the shorted condition. Replacement of the two components, the diode and the MOV, restored the monitor to its normal operating condition.

In addition, to minimize power dissipation during the turn-off interval, the diodes must be fast-recovery types.

**Switched-mode power supply circuits**

Figures 8A, B, and C illustrate the operation of a step-down switched-mode regulator, a step-up switched-mode regulator, and an inverting switched-mode regulator through equivalent circuits. In each of the circuits, the inductor stores energy when the switch — representing the control device — closes. With the circuit of Figure 8A, opening the switch allows diode D1 to establish a path for the flow of  $I_{L1}$  or the load current. With this, the circuit transfers energy during the time that the switch opens.

Moving to Figure 8B, the coil seen in the preceding figure represents the primary of a transformer. The dc-isolated secondary of the transformer provides the output voltage and current for the circuit. Depending on the design needs, the output voltage and current may set up either an alternating current or a rectified and filtered direct current. Defined as a parallel switched-mode regulator, the circuit shown in Figure 8C often appears as the flyback circuit for a color television receiver. A switched-mode regulator used

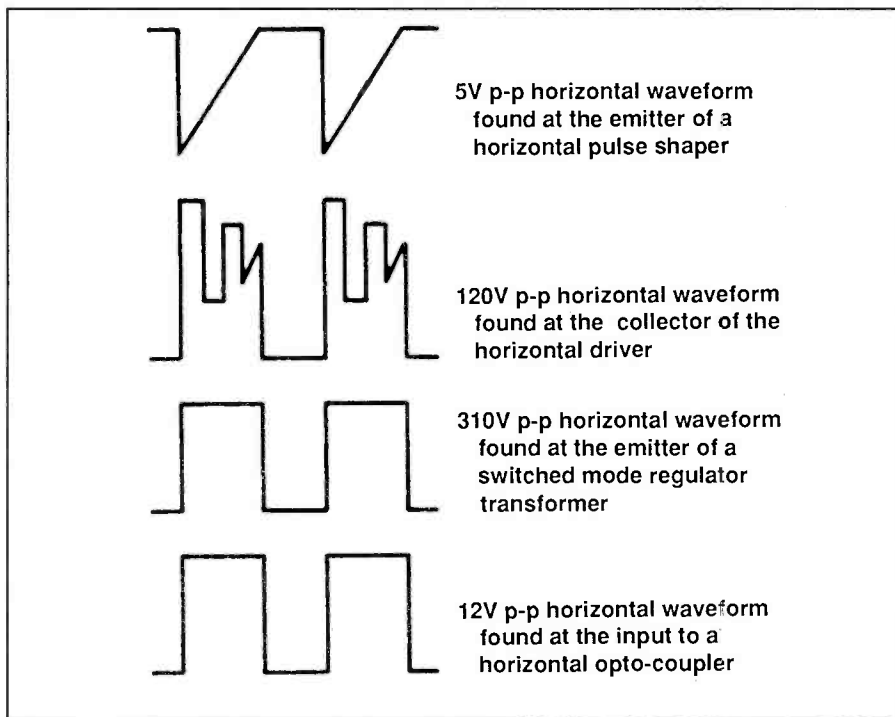

**Figure 11.** Shown here are samples of typical waveforms found in the horizontal circuit of a scan-derived television power supply.

as a flyback transformer in a color television receiver operates at the horizontal frequency rate of 15,750Hz.

### Troubleshooting switched-mode power supply problems

Many technicians consider troubleshooting a switched-mode power supply to be the most difficult troubleshooting task they perform. Part of this feeling stems from the interdependence of the components found in the supply. Proper operation of the supply requires that the components function as a unit. The failure of an SMPS often claims a number of components in the supply.

In addition, many SMPS units do not have any type of overload protection and may suffer a catastrophic failure under heavy load conditions. For example, a heavy load condition may place switching devices such as bipolar transistors under additional stress and cause an early failure. A power line spike that occurs during turn on can destroy the switcher.

When attaching test equipment to an SMPS, always ensure that the test probe is securely fastened to the component under test. General test procedures call for connecting or disconnecting any test leads with the unit under test unpowered and unplugged. If you must connect test

probes under live conditions, cover all but the tip of the probe with electrical tape. In addition, clip the reference, or ground, of the multimeter or oscilloscope to an appropriate ground point so that only one hand is required when testing the circuit.

### Discharging the main filter capacitors

An SMPS should discharge capacitors quickly when powered off. However, good test procedures always require the discharge of the filter capacitors. While the capacitors connect to ground through bleeder resistors and should drain quickly, the resistors can fail. To discharge a filter capacitor, connect a high wattage resistor with a value that matches the working voltage of the capacitor from the positive terminal to ground. As an example of the appropriate resistor value to use, a 2k $\Omega$ , 10W, resistor will discharge a 400 $\mu$  200Vdc capacitor.

### Troubleshooting SMPS systems with test equipment

Even though we can rely on our sight and smell to find damaged components in a switched-mode power supply, the application of test equipment becomes a valuable resource for locating a defective part or parts. The efficient troubleshooting of

an SMPS requires the use of a variable ac transformer, a multimeter, an oscilloscope, a semiconductor tester, and a capacitor tester. A high-quality multimeter is useful for checking the quality of diodes and transistors and for monitoring voltage levels. An oscilloscope is essential for evaluating and measuring waveforms. In many cases, a component defect will become apparent only through out-of-circuit tests performed with the aid of a component tester.

### Variable AC transformers

When troubleshooting SMPS systems, a variable ac transformer (frequently called a "variac" after the trademarked name of a variable transformer that is no longer manufactured) provides an easy method for testing a circuit or unit without applying the full line voltage and for testing the ability of the system to regulate. After repairing an SMPS, use the variac to run the input voltage for the SMPS up to 1.2 times the normal ac line voltage and then reduce the voltage to nearly half of the line voltage.

### Dummy loads

Any test of an SMPS should be conducted without the connection of the original load. The use of a dummy load protects not only the circuits that follow the power supply but also protects the power supply in case a fault exists in the original load. Many technicians use a series light bulb as a dummy load during the testing of switching power supplies.

When working with dummy loads, connect a load to each of the supply lines in the SMPS. Some SMPS designs will not initialize without a load on each line.

A test of the power supply under operating conditions usually requires a load that is about 20% of the original, full load. Then, using the variac, slowly increase the input voltage to the supply. As you increase this voltage, the primary capacitors should charge and disclose any possible shorted or open capacitors.

### Using an oscilloscope to test the SMPS

Given the complexity of a switched-mode power supply, a wide-band oscilloscope becomes especially useful. When checking the operating performance of the switching device, use the oscilloscope



to evaluate the waveform at the base and collector of a switching transistor or the drain of a MOSFET. For scan-derived power supplies, the use of an oscilloscope to confirm that oscillation exists will save a large amount of repair time.

The procedure for confirming the presence of oscillation first involves setting the variable ac transformer to 0V. In addition, remember that the repair procedure also involves working on the "hot" side of the iso-hot chassis. Always verify that the connections of the test equipment attach to the proper ground. If testing a switching transistor, attach the oscilloscope test probe to the collector of the transistor. If testing a switching MOSFET, attach the probe to the drain.

Slowly increase the variable ac transformer setting during the measurement at the switcher and monitor the shape of the waveform. The measured waveform should resemble the waveform in Figure 9. While increasing the variac setting, also listen for squealing noises. Any unusual noise indicates that other problems exist in the scan-derived power supply.

### Typical SMPS problems and symptoms

Troubleshooting an SMPS problem requires a consistent problem-solving procedure, including:

- A check of the B+ voltage;
- A verification of the presence of start-up voltages in a scan-derived supply;
- A verification of the presence of oscillation in a scan-derived power supply;
- A check of the SMPS output voltage;
- A check for regulation.

By checking for the presence of B+, we can narrow the search for the problem source from the entire SMPS to the switching device, the bridge rectifier, or the transformer. The additional check for a start-up voltage in a scan-derived power supply discloses whether or not the power supply has the proper voltage-current source. In addition to the check for start-up voltage, also check for the presence of oscillation in the scan-derived power supply. As shown in the discussion about oscilloscope checks, both the presence and the appearance of the waveform at the switcher are important. After verifying the operation of the SMPS, check the quality of the output voltage. Here, we want to check for proper voltage levels

throughout the power supply and for the proper regulation of the output voltage.

### Common problems

Many times, typical problems account for the failure of a switched-mode power supply. Some of those problems involve blown supply fuses, open fusible resistors, high amounts of ripple in one or more output lines, an audible whine with a lower-than-normal voltage at one output, and intermittent power cycling. In many cases, bad solder connections within the SMPS can cause symptoms to appear that mimic component-caused failures.

The blown supply fuse problem may occur because of a shorted switched-mode power transistor or other semiconductors found in the supply. While a fault in the start-up circuit for the supply may cause fusible resistors to open and shut down the supply, the main power supply fuse will not open. When considering ripple in the output lines, check for ripple at the line frequency of 60Hz or ripple occurring at the switching frequency of 10kHz or more. A dried filter capacitor connected in the main supply will cause an output line to have a 60Hz ripple while a dried filter capacitor connected in a specific output line will cause the higher frequency ripple in the output.

The last two symptoms — audible whine with a lower-than-normal voltage and periodic power cycling — involve shorted semiconductors, a fault in the regulator circuitry, a fault in the overvoltage sensing circuitry, or a bad controller. Usually, the failure of a switching transistor is accompanied by the failure of other semiconductors in the circuit. In some cases, though, a switching transistor will not have the voltage rating needed to withstand the strain caused by the constant on and off switching.

As you have read through the troubleshooting materials, it should become obvious that a large number of problems can cause the receiver to go into shut-down. Troubleshooting of switched-mode power supplies involves signals that begin at the ac voltage input, the horizontal oscillator, and voltage doubler circuits. As the switched-mode power supply operates, an integrated flyback transformer produces dc voltages for the remainder of the chassis.

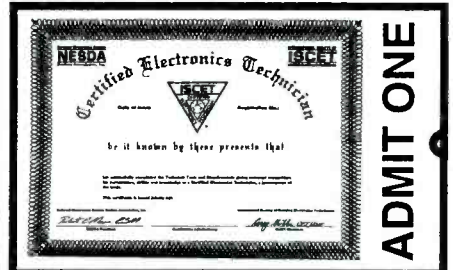

## Your Ticket to SUCCESS

More than 40,000 technicians have gained admittance worldwide as certified professionals. Let your ticket start opening doors for you. ISCED offers Journeyman certification in Consumer Electronics, Industrial, Medical, Communications, Radar, Computer and Video. For more information, contact the **International Society of Certified Electronics Technicians, 2708 West Berry Street Fort Worth TX 76109; (817) 921-9101**

Name \_\_\_\_\_  
 Address \_\_\_\_\_  
 City \_\_\_\_\_  
 State \_\_\_\_\_ Zip \_\_\_\_\_  
 Send material about ISCED and becoming certified  
 Send one "Study Guide for the Associate Level CET Test."  
 Enclosed is \$10 (inc. postage).

Circle (75) on Reply Card

### STORE-TRAK

**#1 Service Software**

- Most Affordable
- Easiest to use

**Call for info and free gift!**

**(888) 377-8771**  
[www.sbsdirect.com](http://www.sbsdirect.com)

Circle (70) on Reply Card

### National Computer Association

The National Computer Association is the Professionals' Choice for securing a future in the computer industry. We make the computer industry a better place for our members to work by uniting together and working to reverse the trend of high overhead and low profits.

Please See Our Ad on Page 49  
 or Visit Our Website at  
[www.nca-net.com](http://www.nca-net.com)

**1-800-615-6224**

## HERMAN ELECTRONICS

Visit our Home Page at  
[hermanelectronics.com](http://hermanelectronics.com)

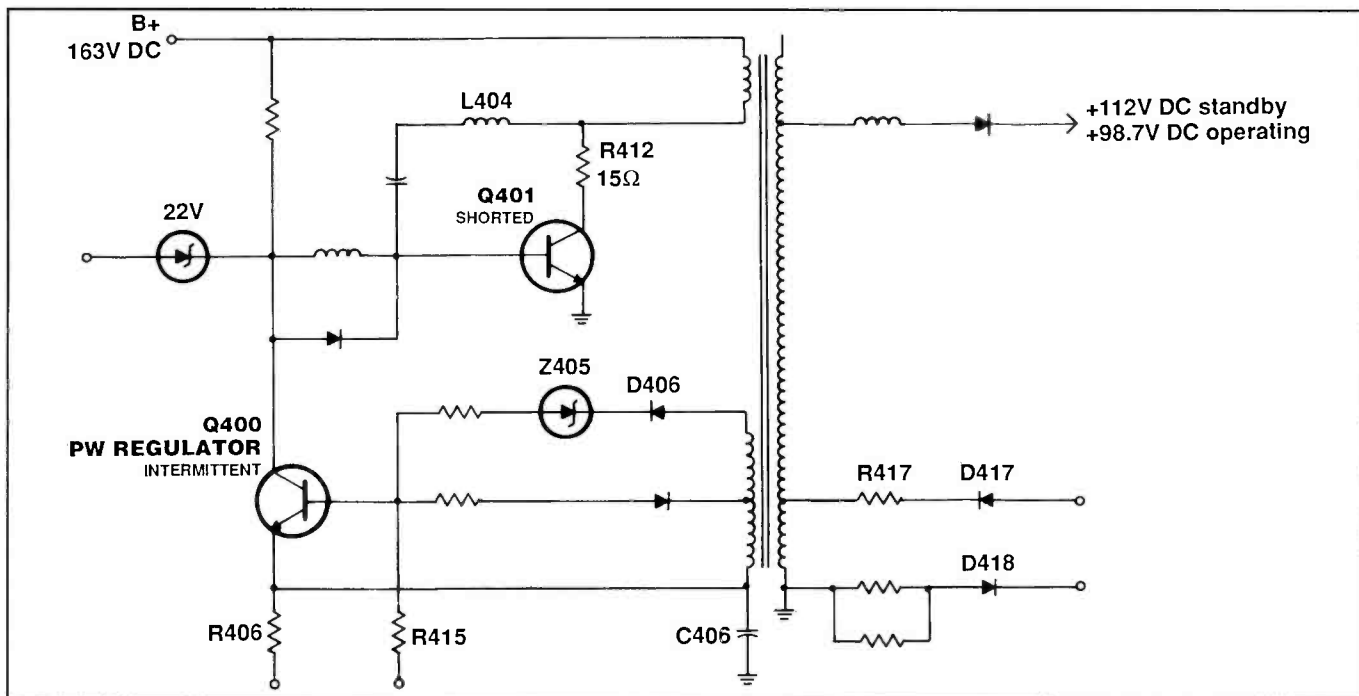

Figure 12. This is the schematic diagram of the switched-mode power supply of a Sylvania Model RAJ147 television set.

### Locating SMPS switching problems

If the SMPS utilizes a power transistor as a switching device and the power supply fails, always test the transistor for shorted and open junctions. The partial failure of a switching transistor often results from leakage or a change within the operating parameters of the semiconductor. Most new SMPS units rely on either an SCR or a MOSFET as a switching device. Testing either an SCR or MOSFET requires a multimeter for basic tests, such as a shorted condition, and additional test equipment for any other tests. When replacing a switching device, always use an exact replacement as recommended by the manufacturer.

### SMPS capacitor problems

Any switched-mode power supply design allows a large amount of current to flow through electrolytic capacitors. In some cases, the repeated operation of the SMPS system will cause the capacitors to short internally or develop an intermediate open condition. Under high load conditions, a capacitor may open and then "heal" at line rates. Many times, discoloration or slightly bulged appearance will show that the capacitor has begun to fail.

Figure 10 shows a pi filter normally found on the auxiliary power supply lines of an SMPS. When the capacitor on the input side of the filter fails, the inductor

absorbs most of the switching voltage from the transformer and the rectifier diodes. As a result, the regulator transistor works harder to generate the +5Vdc desired at the output. With this additional load on the power supply, other capacitors in the supply begin to open.

### SMPS power cycling problems

Many SMPS problems involve a dead supply and a sound that either resembles a tweet-tweet-tweet or a flub-flub-flub. In addition, a fault of this nature may cause display LEDs to flash, or, with televisions, may allow a partial raster to appear. Most power cycling problems result from a shorted component in the auxiliary power supply. Those components include diodes, capacitors, and SCRs in the overvoltage crowbar circuit.

A failure in the overvoltage sensing circuit will also cause a power cycling problem to occur. If you suspect a failure of this type, check the SCR in the crowbar circuit. Low-power SCRs often operate as control devices in the crowbar circuits used for overvoltage and over current protection. Generally, out-of-circuit tests on the SCRs will disclose any faults in those devices. If the power supply fails to energize because of a failure in the protection circuits, the problem may trace back to a shorted SCR.

After checking the component, check

for any short circuit conditions on the output lines connected to the SCR. Then, remove the SCR and use a variac to slowly increase the input voltage while monitoring the voltage at the output line. Checking the voltage at this point will show whether the voltage is going past the overvoltage level; if the voltage remains clamped at a low level; or if the voltage stays at the correct level under normal load conditions. A momentary overvoltage spike that occurs at the turn-on of the receiver will cause the overvoltage circuit to react.

### Use your senses

Aside from checking the components in an SMPS, always use your senses to find a possible fault. After checking the fuse and unplugging the unit, take a moment to thoroughly dust the power supply with a soft cloth and Q-tips. Many times, dust will cause the failure of a power supply. In addition, survey the power supply for any possible open circuit conditions, any possible paths for a short circuit, and burned components. After completing those checks, disconnect the secondary loads from the supply. Then, use an external voltage supply to power up each auxiliary circuit.

### Testing the SMPS after the repair

After repairing an SMPS, replace the load normally connected to the supply

with a dummy load. The primary load requires the most consideration with smaller loads applied to the other outputs. Depending on the application, the load should vary from 2Ω to 3Ω at 15W, to 25Ω to 50Ω at 2W to 5W. Personal computers usually have a smaller load on a +5Vdc output while VCRs have the larger load on a +12Vdc output. Using a variac, slowly increase the input voltage while observing the main output voltage. As the input voltage reaches 50% of its normal level, the output should reach its normal operating value.

### Troubleshooting auxiliary power supply problems

Often, the shutdown symptom occurs because of a defect in the auxiliary power supply section. With linear power supplies, separate windings of the power transformer secondary may supply different B+ voltages. Referring back to the previous sections, a switched-mode power supply usually has low-voltage power supply circuits operating from voltages taken from the flyback transformer. As you know, the parts of a receiver tied to

the flyback secondary range from the tuner and audio sections to the horizontal driver and output sections. When we consider either type of auxiliary power supply and the associated circuits, note the number of diodes and electrolytic filter capacitors used in those circuits. A defect in any one of the diodes or capacitors can either cause shutdown or a defect traceable back to several different stages.

Despite the differences seen between linear and switched-mode power supplies, certain patterns remain in place. Each auxiliary power supply extending from a separate winding on an IHVT will have rectification, filtering, and regulation. In most cases, you will find that a low-voltage power supply consists of a bridge rectifier, a high voltage filter capacitor, and a combination of transistor and zener diode regulation. Knowing that each low voltage circuit is likely to have these basic parts makes troubleshooting the auxiliary power circuit easier.

In addition to knowing about the basic parts of the sub-system, we can also point to the various functions of the stages attached to the auxiliary supply. For example, if the receiver has a symptom of

no sound, but normal picture, and normal raster, we concentrate on the auxiliary line that supplies the audio output circuit rather than the line tied to the vertical circuits. An incorrect voltage in the auxiliary line indicates either that the power supply has a defect or that a defect in the supplied circuit has caused an overload.

All this sounds rather simple until we consider that a short or lower-than-normal resistance in an auxiliary circuit may cause abnormal loading on the power supply, additional damage to the rectifier diode, and the shutting down of the entire system. In late model televisions, shutdown occurs because of the use of voltages derived from the secondary winding of an IHVT. With the coils wound on the same transformer core as the high voltage windings, the chassis may start up and then quickly shut down. At times, the shutdown may be preceded by a symptom, such as a white horizontal line stretching across the center of the screen, that shows the location of the defect.

If the receiver goes into shutdown, shutdown circuits either monitor the amplitude of the flyback pulse or compare the flyback pulse amplitude to the



The Professional  
**Electronics Technicians Association**  
and the **Satellite Dealers Association**

## Certified Satellite/ Antenna Technicians

Four types of recognition for technicians engaged in small and large satellite dish installation, rooftop antennas and video distribution are available from ETA and SDA. Write for a free brochure (or circle your reply card).

### THE ANTENNA BOOKS #1 & 2

These two new study guides have all the information you need to become an expert in providing customers with the best reception, interconnection and signal distribution methods. They are written by multiple authors, each with years of experience. They contain quizzes at the end of each chapter, plus an overall practice test similar to that used for the actual certification exams in these categories. Both Antenna Books can be ordered from ETA-SDA for \$44 (incl S & H)

Join the **Antenna Experts Group** and SDA for just \$25 and get a free listing in the AEG page on the ETA-SDA Web Site.

765-653-4301 - 765-653-8262 Fax  
602 N Jackson  
Greencastle, In 46135

<http://www.eta-sda.com>

e-mail: [eta@indy.tdsnet.com](mailto:eta@indy.tdsnet.com)

Circle (77) on Reply Card



**Join the Thousands  
of Professionals  
Who Are Reaping  
the Rewards Today**

Joining the NCA is your best choice for securing your future in the computer industry.

As a trade association of over 2,000 professional VARs, the NCA is having the impact that no one company can have alone. As an association member, you'll now be able to share ideas and be armed with the tools that can reverse the trend of high operating costs and low revenues. These cooperative efforts will continually strengthen and help secure your place in the computer industry for many years to come. In addition to becoming a professional member of the NCA, your benefits include the following:

- |                                     |                                     |
|-------------------------------------|-------------------------------------|
| <b>Toll-Free HelpLine</b>           | <b>Specialized Product Programs</b> |
| <b>Certification Programs</b>       | <b>Media Replication Services</b>   |
| <b>OEM Software Opportunities</b>   | <b>Investment Services</b>          |
| <b>Professional Reference Guide</b> | <b>Seminar Training Programs</b>    |
| <b>Educational Programs</b>         | <b>Extended Warranty Programs</b>   |
| <b>Product Search Program</b>       | <b>Technical Support References</b> |
| <b>Equipment Leasing Services</b>   | <b>Recycling Programs</b>           |
| <b>Telecommunication Services</b>   | <b>Monthly Newsletter</b>           |
| <b>Credit Card Services</b>         | <b>Web Hosting Services</b>         |
| <b>Financial Services</b>           | <b>NCA Logo and Decal</b>           |
| <b>Equipment Rentals</b>            | <b>Certificate of Membership</b>    |
| <b>Travel Services</b>              | <b>Membership ID Card</b>           |

Please contact the National Computer Association to receive complete applications.

◆ **800.615.6224** ◆

◆ National Computer Association ◆  
13555 Automobile Blvd ◆ Suite 240 ◆ Clearwater, FL 33762  
[nca@gte.net](mailto:nca@gte.net) ◆ [www.nca-net.com](http://www.nca-net.com)

Circle (76) on Reply Card

amplitude of the current. As mentioned, all this traces back to the need for regulating the high voltage at the CRT second anode and reducing the chances for x-ray emission at the picture tube.

### Troubleshooting overvoltage/ overcurrent shutdown problems

The troubleshooting of a shutdown problem is complicated by designs that tie the start-up voltages for a television receiver to the horizontal oscillator and driver stages. With the exception of the

horizontal output transistor, all stages operate from dc voltages rectified from the horizontal sweep. Any interruption in those voltages allows capacitors to discharge and results in shutdown of all the circuits. From a troubleshooting perspective, the absence of clues when the set is dead (no raster, no sound, no picture) makes problem-solving more difficult.

For that reason, some basic procedures are needed. When encountering a receiver locked into shutdown, power up the receiver and check for any symptoms. A

shutdown preceded by normal picture decreasing to a thin horizontal line indicates that a problem in the vertical circuits has overloaded the low voltage power supply tied to the IHVT. A raster that grows brighter or is limited to only one color just before shutdown occurs should lead to an investigation of the CRT and a possible overload in the video circuits.

Always use an isolation transformer, a variable ac transformer, and a good high voltage probe when troubleshooting the shutdown condition. The use of a variable ac transformer allows the testing of the receiver under conditions where the ac line voltage begins at 65Vac. With only that low level of line voltage, the receiver will develop some high voltage. Increasing the line voltage while measuring the high voltage should show whether excessive high voltage has caused the shutdown. An excessive high voltage condition becomes apparent if the high voltage reaches 26kV or higher at the 80Vac level. With this type of defect, shutdown will occur as the line voltage reaches the 80Vac to 100Vac level.

In addition to monitoring the voltage levels, use an oscilloscope to check waveforms around the horizontal output transformer. Figure 11 shows samples of typical waveforms found in the horizontal circuit of a scan-derived television power supply. Again using the variable ac transformer and the isolation transformer, increase the line voltage to the point just below where shutdown occurs. Then, observe the waveforms at the base and collector of the horizontal output transistor. Distortion of the base waveform should direct your attention to possible overloads in the horizontal oscillator and driver circuits.

Distortion of the collector waveform, such as reduced retrace pulses or distorted pulses in between the retrace pulses, indicates that an overload exists in the stages following the output transistor. In some cases, shorted turns in the yoke or the horizontal output transformer can overload the power supply. In others, a shorted rectifier diode or shorted filter capacitor in an auxiliary supply line can overload the secondary of the IHVT. As shown earlier, a defective regulator can cause the voltage at the horizontal output transistor collector to increase to the point where shutdown occurs. ■



**Use your FREE  
Reader Service card for more  
information on companies  
advertising in this issue.**

<b>PHOTOFACTS</b>	
<b>EMERSON</b>	
TC2555D (Suffix C) .....	4059
<b>HITACHI</b>	
M7LXU .....	4054
36CX35B .....	4054
<b>PANASONIC</b>	
DP304 .....	4058
AMDP304 .....	4058
CT-13R3W .....	4058
CT-13R18CW .....	4058
CT-13R18W .....	4058
CT-13R19CW .....	4058
CT-13R19W .....	4058
<b>PHILIPS/MAGNAVOX</b>	
HD1918C121 .....	4062
HD1918C122 .....	4062
HD1918C125 .....	4062
HD1918C127 .....	4062
PR1304B101 .....	4056
PR1904B101 .....	4056
<b>RCA</b>	
CTC197CA .....	4052
F32674SBFM1 .....	4052
F36674ETFM1 .....	4052
<b>SANYO</b>	
DS19730 .....	4064
DS26950 .....	4060
19730-01 .....	4064
19730-02 .....	4064
26950-00 .....	4060
<b>SHARP</b>	
CK13M10 .....	4057
CK13M15 .....	4057
CK20S10 .....	4061
VC-H972U .....	VCR-303
13K-M100 .....	4057
13K-M150 .....	4057
20K-S100 .....	4061
21MK50 .....	4061
<b>SYLVANIA</b>	
4819LT .....	4053
<b>TOSHIBA</b>	
CE19H15 .....	4055
CF13H22 .....	4063
CF19H22 .....	4063
CF19H32 .....	4055
TAC9800 .....	4055
TAC9801 .....	4063
TAC9802 .....	4063
TAC9803 .....	4055

# Startup-shutdown problems in Philips' A8 chassis

by Bob Rose

If there is an axiom in the electronics service business, it has to be, "Look how rapidly things change." Several years ago, we could expect changes to occur about once a year. Major changes occurred every two years or so. Now, we servicers see changes in consumer products at least once every six months. I subscribe to Philips' service literature. A part of the subscription includes a "what's new" video that is about an hour long. Once in the Fall/Winter, I preview "what's new for Spring"; once in the early Spring, I preview "what's new for Fall." And the changes are sometimes mind boggling. We get accustomed to a certain way of doing things, and all of a sudden it isn't done that way anymore.

Philips' A8 (and Y6) chassis falls into this category. It uses a new circuit board and sports a new component numbering system. It also contains a new group of integrated circuits that work together in a new configuration. The service literature is also new. I confess that I find the literature a little hard to use. For example, the pins on the microprocessor are not labeled. You can sort of determine what the pin function is, but you will spend more than a little bit of time doing it (Figure 1). The literature does have some helpful features, like part numbers listed on the schematic, rather than exclusively

on the accompanying fiche and a component location grid.

## A new component numbering system

You might be interested in Philips' new component numbering system.

0000	heatsinks
1000	electromechanical crystals, resonators, fuses, switches IR receivers
2000	capacitors
3000	resistors
4000	not in current use (reserved for future applications)
5000	inductors, coils, transformers, ferrite beads
6000	all types of diodes
7000	integrated circuits and transistors
8000	leads, sleeves, wiring
9000	wire jumpers on the printed circuit board

The second digit indicates the following circuit area in the television:

0	tuner and IF area
1	audio
2	luma-chroma
3	CRT board
4	horizontal and vertical components
5	power supply, AC input, switching power supply
6	microprocessor and control system
7	reserved for future use
8	reserved for future use
9	reserved for future use

Rose is an independent consumer electronics business owner and technician.

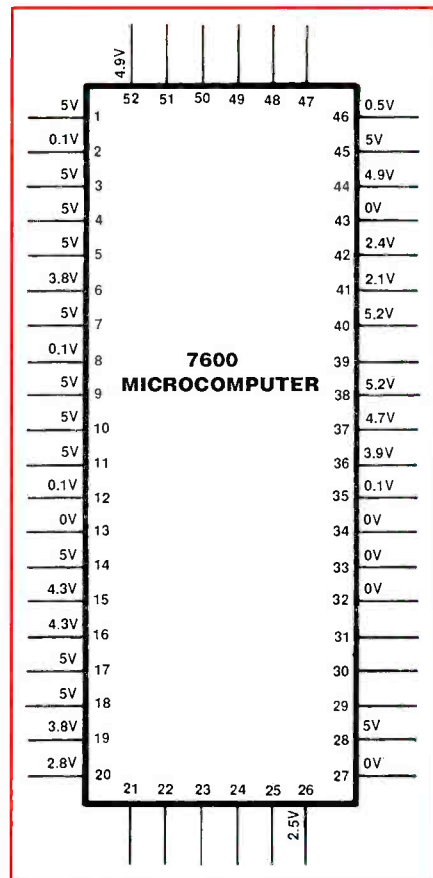

Figure 1. Pinout diagram for the microprocessor in the Philips' A8 (and Y6) chassis.

## A set of new integrated circuits

We need to examine the IC's in the A8 chassis before we get to startup-shutdown problems. We will begin with the microprocessor, IC7600, a highly compact

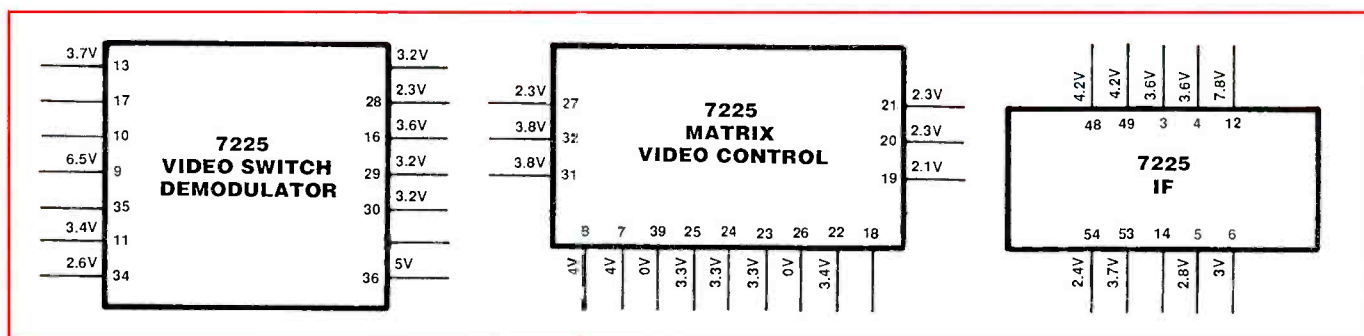
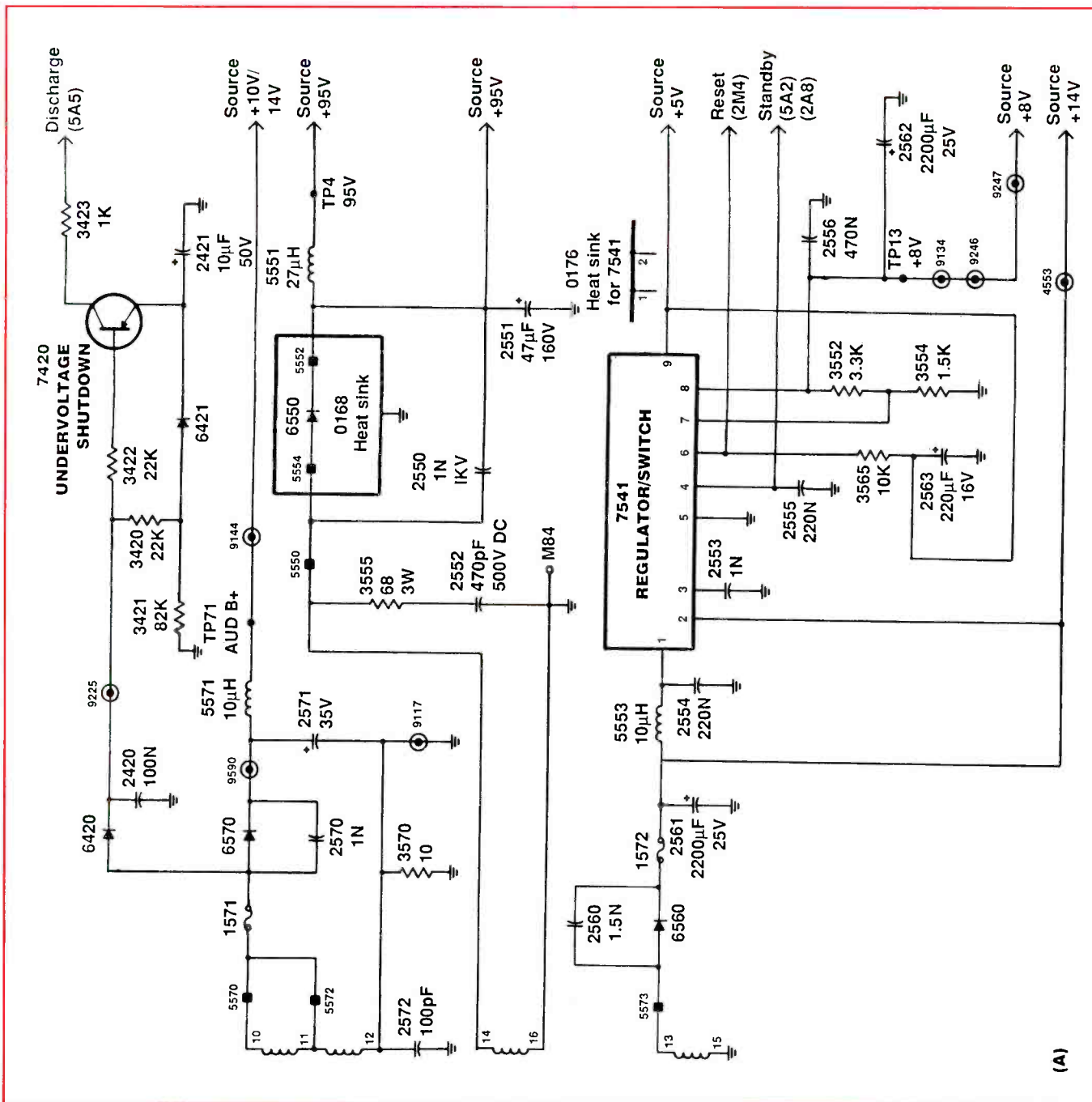

Figure 2. In this set, IC7225, a BIMOS integrated circuit, is the video processing chip. This chip also processes color and luminance and outputs information to the CRT. It demodulates the audio, processes sync, and develops horizontal and vertical drive.



fifty-two pin chip. The relevant pins for our discussion are: pin 52, which supplies 5V VDD; pins 21, 22, and 39, which are connected to ground; pins 41 and 42, which are the oscillator pins; pins 49 and 50, which are the serial data and serial clock lines; pin 43, which is reset; pin 16, which is HEW shutdown input; pin 19, which controls the on-off function and serves as another shutdown input; a horizontal pulse at pin 36; and vertical pulses at pins 37 and 47.

Be advised that clock and data lines are active when the set is on and functioning, not just when the micro receives a request from the user.

The next chip is IC7225 (Figure 2). It is billed as a "BIMOS" integrated circuit and is the video processing chip. It does more than process video, however. It also processes color and luminance and outputs information to the CRT. It demodulates the audio, processes sync, and develops horizontal and vertical drive. We will

be concerned with its control of the deflection circuits, particularly horizontal drive. Pin 37 is the input for horizontal B+. Pin 40 toggles horizontal drive on and off via the standby line to the regulator switch and sends out horizontal drive to the horizontal deflection circuits.

The third chip is IC7541, the regulator/switch (Figure 3A). It receives B+ from the power supply, develops 5V for the microprocessor and remote receiver, is responsible for reset voltage to the microproces-

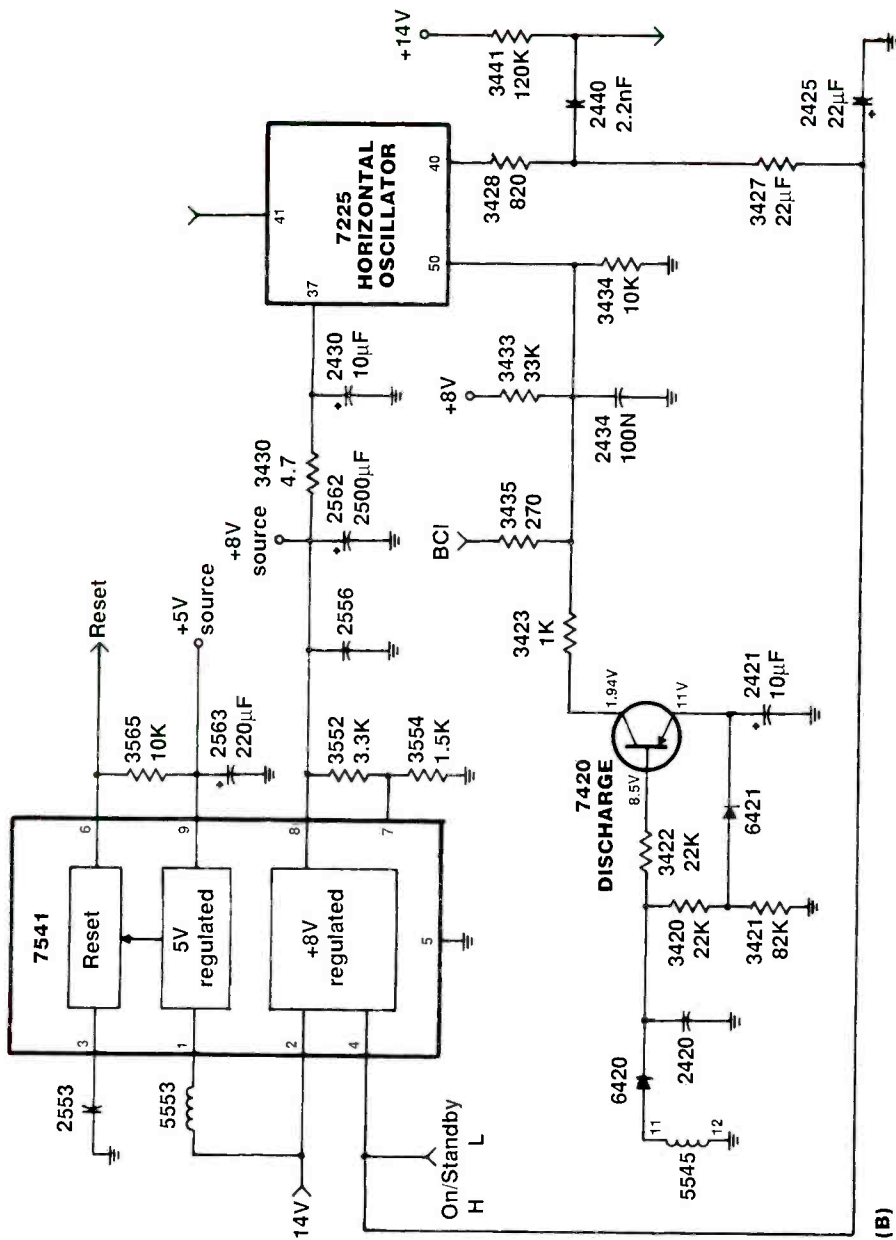

← **Figure 3. (A)** In this set, IC7541, the regulator/switch, receives B+ from the power supply, develops 5V for the micro and remote receiver and is responsible for reset voltage to the micro. **(B)** When turned on by the micro at pin 4, IC7541 supplies 8V to IC 7225 to turn on horizontal drive.

processor, and when turned on by the microprocessor at pin 4, supplies 8V to IC 7225 (Figure 3B) to turn on horizontal drive.

The A8 chassis uses a memory integrated circuit, IC7620. Be advised that these chips constantly chat with each other via the clock and data lines when the TV is up and running. We are accustomed to seeing activity on these lines only when the micro receives a request via front panel controls or the remote transmitter. This chassis departs from

what we are accustomed to servicing. If something interferes with bus activity, the chassis *will not* start or *will* shut off if it has been turned on. Neither will it start if the servicer removes the memory IC. Like you, I am accustomed to checking a Philips' memory chip for a defect by removing it from the circuit. In the past, the memory IC merely stored information for the customer in the event the set lost power. It is now an integral part of the working TV. If you service a set that has

no bus activity, you can desolder the chip to see if it is dragging the clock and data lines down. But IC7620 has to be up and working for the TV to work.

The last IC I will mention is IC7401 (Figure 4). Note that it requires a positive and negative voltage (both are scan-derived) to work. The obvious question is, "Why mention the vertical output IC in an article about startup-shutdown problems?" The answer is, this set will attempt to start and then shut down if the micro does not receive an indication that IC7401 is working! Something new, you see. Incidentally, some of Zenith's "A Line" televisions will incorporate this design. The rationale is that it will save the CRT in the event of vertical failure.

### Shutdown circuits

The microprocessor receives an on command from the front panel control or the remote control. It executes the command by sending a "high" out through pin 19. The high is routed to pin 4 of IC7514, raising the voltage from about 0.7V to about 3.2V. The regulator/switch turns on its 8V source at pin 8. The 8V is applied to IC7225 pins 37 and 40, causing the horizontal oscillator to start, which fires up horizontal deflection, and therefore the rest of the television.

As far as I can determine, seven circuits can keep the television from starting up or cause it to shutdown once it has started. If my experience is typical, when a shutdown circuit is activated, the TV will startup and in just about three seconds go off. In other words, shutdown is not "immediate." Close to it but not immediately after turn on.

(1) The most obvious and most common is a failure in the power supply. The entire supply will be dead, or there will be a failure in the 14V supply from pin 13 of T5545 (Figure 5). Remember, the 14V supplies IC7541 and, is therefore the supply for the 5V standby, as well as the 8V VCC to the video processor IC.

(2) The next most common problem will be loss of vertical deflection. The TV will

startup and shutdown two to three seconds after the user issues an on command.

If I remember correctly, the LED on the front panel that indicates an "on" status will blink at you to indicate a shut-down situation exists.

I have seen two instances of shutdown due to failure of the vertical deflection circuits. In one instance, the vertical output IC (IC7401) needed to be resoldered. In the other instance, I had to replace a shorted diode in the -13V supply (D6449), resistor (R3413) and the vertical output IC. Philips has issued a service bulletin

detailing this particular problem. I will caution you to use OEM parts if it is at all possible. The symbols on the schematic, triangles with an exclamation mark inside, tell you the parts are critical and incorporate certain safety features which generic parts may not have!

The next five items could be labeled "shutdown circuits."

(3) HEW shutdown. The HEW circuit monitors the high voltage via pin 9 of the IFT (Figure 5). The voltage is rectified by D6451 and filtered by C2455 and is then applied to the cathode of zener diode

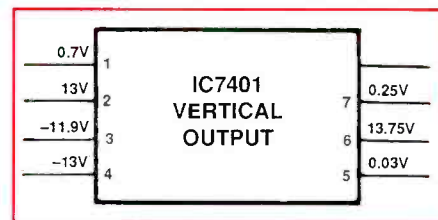

**Figure 4.** Note that IC7401, the vertical output IC requires a positive and negative voltage (both are scan-derived) to work. This set will attempt to start, but if the microprocessor does not receive an indication that IC 7401 is working, it will then shut down. This is something new. Some of Zenith's "A Line" televisions will incorporate this design. The rationale is that it will save the CRT in the event of vertical failure.

## ES&T READER SURVEY

**It's a mini survey about you.**

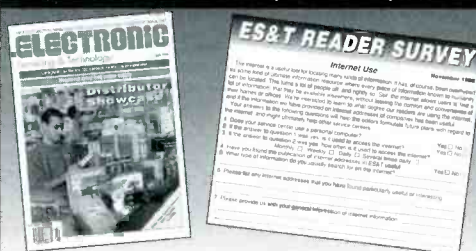

Bound into this issue is the ES&T Reader Survey card

We would like to hear about the problems you face, the opportunities you see and the equipment you use during the course of your work day.

The postage is paid. All you have to do is fill it out and mail it.

What could be easier?

Please fill yours out and mail it today.

## NEWS (from page 4)

H.R. 2281, a Clinton Administration measure to implement the treaties negotiated at the World Intellectual Property Organization, contains restrictions on new devices that might be used for home recording. The bill was approved by the House Judiciary Committee in April and is under consideration in the House Commerce Committee. Similar legislation (S. 2037) passed the Senate in May.

Shapiro emphasized the industry's willingness to work toward solutions and the ratification of WIPO treaties, while asserting its opposition to H.R. 2281: "We are willing to work with representatives of content and other industries to identify balanced technical and legislative solutions. We did it in the Home Recording Act. The only thing we cannot do is support legislation that would require us, in the design of new products, to respect unknown and unknowable technical approaches toward undefined ends that may be entirely unrelated to protection against copyright infringement." CEMA and HRRC are particularly concerned that the legislation would reverse

the Supreme Court decision in the Sony Betamax case which established the legality of VCRs and videotaping.

CEMA is a sector of the Electronic Industries Alliance (EIA), the 74-year-old Arlington, Virginia-based trade organization representing all facets of electronics manufacturing. CEMA represents U.S. manufacturers of audio, video, accessories, mobile electronics, communication, information, and multimedia products which are sold through consumer channels.

HRRC includes consumer electronics manufacturers and retailers, consumer organizations, service associations, and others interested in the personal, non-commercial use of consumer electronics recording equipment. The coalition was formed in 1981, in response to a 9th Circuit appellate opinion, and proposed legislation, that would have banned the sale of home recording devices to consumers. The Supreme Court subsequently reversed the decision and preserved the right to sell home video recorders in its 1984 "Betamax" opinion.

ZD6451. When the monitored voltage reaches ZD6451's zener point, it turns on, which turns on Q7650, which places a low on pin 16 of the micro. The micro responds by turning the TV off.

(4) If the set loses the 13V scan-derived voltage, the micro will turn the set off. Q7608 is the +13V monitor (Figure 5). If voltage fails during operation or fails to come up, the transistor conducts placing a low on pin 19 of the micro, which turns the set off.

(5) Q7420 (Figure 3) is the undervoltage monitor. If the voltage falls below a certain point, it turns on placing a low on pin 50 of IC7225, which turns the horizontal oscillator off. The reason given for this shutdown input is that it keeps spikes off the horizontal deflection circuit, spikes that can, as we know, cause serious and expensive damage.

(6) Shutdown can occur if pin 40 of IC7225 loses its VCC.

(7) A defect on the data bus that causes loss of serial and/or clock data will also cause either no start or shutdown.

### Troubleshooting procedure

Neat, isn't it? But there is still that troubling question: How do you troubleshoot it? Remember, now, this information is applicable both to the Y6 and A8 chassis. Well, Philips recommends the procedure I am about to give you, and I can testify it really does work and works well enough to save the servicer time. Let me assume that you have taken the time to check for the presence of necessary operating voltages!

First, desolder one side of R3657. Either side will do. When you remove it,



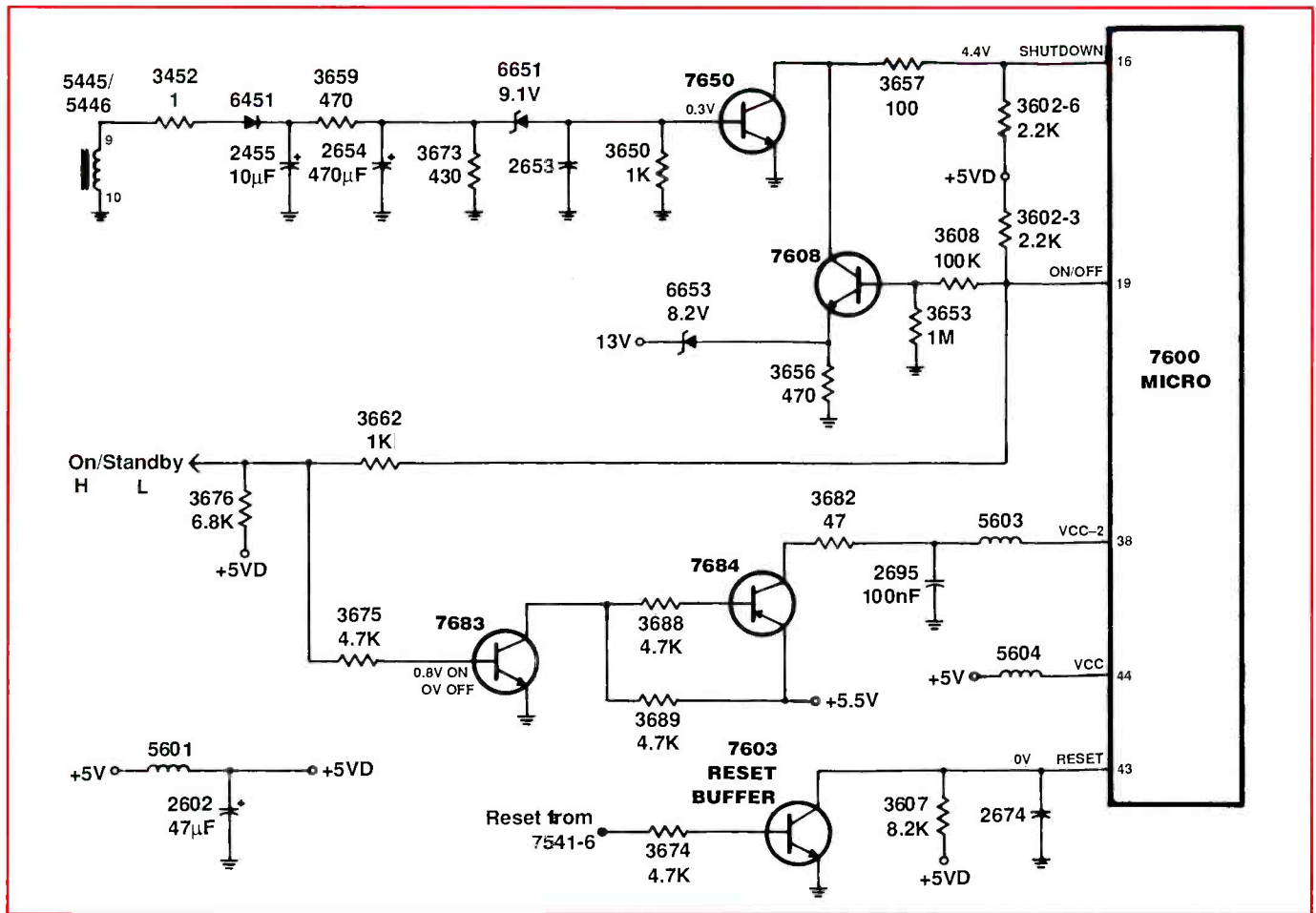

**Figure 5.** If this set fails to start up, the most obvious and most common is a failure in the power supply. The entire supply will be dead, or there will be a failure in the 14V supply from pin 13 of T5545.

you remove the shutdown inputs it routes to the microprocessor.

Second, unsolder pin 19 of the micro. This keeps a low from turning the TV off. It could be a low the micro generates or a low generated when the +13V scan-derived source fails.

Third, apply ac and press the power button. Don't forget to press the power button. Even if raster appears, the micro has to receive an on command to turn the rest of the TV on. The television will now respond in one of two ways. It will either come on, or it will fail to come on, resulting in the "dead set syndrome."

If it comes on with full raster, you can check the collector of Q7650 to determine if the HEW circuit has been activated. If the voltage is at logic low, take a few other voltage measurements to see whether the problem is a defect in the HEW circuit or the high voltage is indeed too high. Your problem will most likely be in one or the other of these two circuits.

If the set comes on with a line across

the center of the screen indicating loss of vertical deflection, determine if the problem is loss of the +13V or a failure in the vertical circuit related to the vertical output IC and/or its associated circuits (like the yoke).

If the set does not come, the signal processor IC is not working. Before you condemn it, check for the presence of 8V B+ and clock and data activity. If you do not have the necessary VCC, follow the 8V line back to the regulator/switch to determine why it is absent. With pin 19 of the micro lifted, there should be voltage at its control pin. Correct voltage at pin 4 but no output at pin 8 tells you the regulator/switch IC is defective. If you have 8V at the signal processor, confirm clock and data activity to the chip.

If there is no clock and data activity, wick out pins 49 and 50 of the micro. If the pins then become active, resolder them and wick out the necessary pins of the memory IC. If the lines become active, you have isolated the problem to the memory IC. I

have known of one case when a corrupted IC7620 resulted in a dead set. If the memory IC is not the problem, proceed to the tuner and the signal processor itself. You will proceed with the knowledge the micro is not the problem and that something on the bus line is holding the lines low.

If you have VCC and clock and data activity to the signal processor but no horizontal drive, then you have a defective IC. I have found these chips to be very reliable, having had just one fail due to lightning. Its failure was related to the color circuits. In other words, I assume the chip is good until it has been proven defective beyond a reasonable doubt.

Now a final word. If you need to troubleshoot the horizontal circuit, Philips recommends that you remove the horizontal output transistor and put in its place a 60W light bulb. You minimize the risk of damaging other components or injuring yourself. You will also have a visual reference for the absence or presence of VCC to the transistor. ■

# What Do You Know About Electronics? Volts and jolts

By J. A. Sam Wilson

In a previous issue, I demonstrated that voltage is *not* an electromotive force (EMF). It is, in fact, a measure of "work per unit charge." In science work, it is equal to force multiplied by distance  $w = Fs$  (where  $w$  is work,  $F$  is force, and  $s$  is distance); and, a coulomb is the unit of charge equal to the total charge of about  $6.242 \times 10^{18}$  electrons in a bunch.

Why not call voltage a force? As I have said many times before, you can call a bactrian camel a dromedary camel, but that won't give it two humps. In science, it is very important to call things as they are.

One important case occurs when you are rationalizing units. It is an important way to check an equation to make sure it gives true results. An example of rationalizing units is shown in Figure A.

## The Coulomb — a fundamental particle

I have noted that the electron is *not* a little red particle of matter that carries current around a circuit. In the first place, it is smaller than a wavelength of light, so, it could not possibly have a color.

In the second place, at any time it can be either a particle or a wave (or wave energy). According to the uncertainty principle, you need to use the laws of probability to predict which it is at any time. We're going to take a brief look at one of the laws later in this issue.

Is this going to change how we treat current in a circuit? No! We can continue to treat an electron as a little red ball carrying current. However, when your grandchild comes home from science class trying to surprise you with the true story of the electron, you can lean back and say that you read **ES&T** magazine and you know the real facts. (Maybe you can add something like: The little red ball is called a model.)

## Conventional vs. electron current flow

In the previous issue I said we would

---

Wilson is the electronics theory consultant for **ES&T**.

romp across the theory of statistics and show how it applies to electronics. I don't mean we are going for a full-blown study of statistics. (That would be a four-year college course. Top-level technicians need that like a moose needs a bathing cap.) It is, by the way, one of the most difficult types of mathematics in the mathematicians "tool box".

I'm not, in most cases, going through the process of obtaining a statistical analysis. Instead of "how do you do it?" I'll concentrate on "what good is it?" (with very little of "how to do it").

An electron is an extremely small negative charge of  $1.602 \times 10^{-19}$  coulomb. If you take the reciprocal of that number you find that a coulomb is the total charge of  $1/1.602 \times 10^{-19} = 6.242 \times 10^{18}$  electrons in a little bunch. (No, it is not  $6.28 \times 10^{18}$ .)

In the field of electronics, we put the electron to work. The classical model of the atom has electron particles moving around a nucleus with protons and neutrons in the center. That's the model taught to beginning technicians. However, if we are dealing with electrons moving through a solid material, then we must consider them to be waves rather than particles. If we are constrained to think of electrons as waves, we must use quantum mechanics rather than Newtonian (classical) mechanics. That explains the description of electrons as waves that seems to be contrary.

If you move a negatively-charged particle (in this case a coulomb) away from a positively-charged plate toward a negatively-charged plate, you will have to exert a force through a distance. Remember, work (in science) is equal to force  $\times$  distance. A volt is the work done (in Joules) in moving a fundamental particle (a coulomb) between a + and - charge.

## Volt = Joules/Coulomb

We have already observed that the fundamental charge is a coulomb, when a negative fundamental charge is moved from a positive point toward a negative

A man earns twenty dollars per hour.  
That's  $\frac{20 \text{ dollars}}{\text{hour}}$ .

How much is his base pay for working 40 hours?

Answer:  
base pay =  $20 \text{ dollars} \times 40 \frac{\text{hours}}{\text{hour}}$  (cancel hours)

base pay = 800 dollars

Figure A. The idea behind cancelling units.

point, you are doing work. This plus to minus motion explains the + to - direction used in conventional current flow. It makes good sense to almost everyone who is working in the field of electronics.

I have to point out that many new texts used in electronics technology are now using conventional (+ to -) current flow. It is important that the authors of those books should define the direction of current flow in their articles and books.

If an electron is accelerated through a potential difference of 1V, it will gain a kinetic energy of one electron volt (eV). Kinetic energy is the energy of motion the electron has that allows it to do work. The eV is a unit of energy that is often used to describe the energy the electron gains when it is moved by a potential of one V.

If a charged particle is moved through a voltage potential with a speed that approaches the speed of light, its mass approaches infinity. So, in some cases, the mass of the electron must be taken into consideration when working with some devices, such as a cathode-ray tube.

So far, I have described the coulomb and the effect of certain forces on a coulomb. Also, I have explained why scientists and engineers use what we call conventional current flow.

*The following article is contributed by John Schmid who is a student at Florida*

### DVD technology

CD-ROM technology is soon to be a thing of the past. It is making room for the new technology of Digital Versatile Disc (DVD). "In the same way that CD's slowly supplanted vinyl LP's, . . . DVD will steadily replace CD-ROM." (PC Magazine) This new technology comes in several forms, including DVD-Video and DVD-ROM, and is sure to have a large impact on both the computer and entertainment industries. DVD is capable of serving the needs of a variety of users that was not possible with its predecessors.

"The same physical size as a CD-ROM, a single sided, single layer DVD-ROM has a storage capacity of 4.6G bytes. The double sided, double layer version has a capacity of 17G bytes (enough to store an 8 hour motion picture). (Watson, pg. 1) This means that the double sided DVD is capable of holding the same amount of data as 27 compact disks. This provides a great benefit for the potential users of the DVD technology.

The first release of DVD was designed for playing movies on TV. Although the DVD movie player is sure to occupy a large portion of the DVD market, there are many uses of DVD. "The different types of DVD that have evolved to meet the needs of different types of users are:

- DVD-Video — Offers read-only storage for playback of movies on consumer DVD players connected to a TV, or a DVD drive in a PC.

- DVD-ROM — Read-Only Storage for personal computers, the DVD-ROM format can store video, audio, images, and graphics. It's ideal for interactive games and reference materials.

- DVD-R — Offers write-once/read-many storage for media recording and software development.

- DVD-RAM — Write-many/read-many storage for media recording and software development.

- DVD-Audio — A format especially for music." (Comucon, pg.1) This number of uses make the DVD much more appealing than the CD-ROM.

Currently, DVD movie players have been introduced and offer incredible features that are not available with VHS video players. Some of the advantages are:

- More durable (will not wear out like tapes)

- Better picture quality

- More versatile

The latter is the most remarkable. "With DVD titles, producers could add sound tracks in different languages. They could include interactive versions that would allow for multiple endings, and they could provide controls that let parents set the DVD players to run different versions of a film edited to fit PG, PG-13, R, or NC-17 ratings." (PC Computing) Although DVD player sales have been slow, they will eventually overtake the video movie market. This will most likely occur when rental outlets make the switch to DVD movies.

In the computer industry, the DVD-ROM is available in almost all new computers. The drives are capable of playing DVD's and are CD compatible. There are a growing number of DVD titles being introduced to the market which inevitably will mark the end for the CD-ROM and CD's. DVD technology has also made it possible to watch movies on your PC with the right hardware configuration.

The development and introduction of DVD technology has definitely added a new chapter to both the computer and entertainment industries. The CD and VHS tape are soon to be obsolete with the continued evolution of this technology. They will be forgotten in the same manner as the 8-track tape, vinyl LP's, and the more recent cassette music tape. Even with all its promising characteristics, the DVD will not be here forever. "Toshiba has developed technology that can hold 1,000 times more data than a DVD. Based on Terabit Molecular Memory technology, the next generation discs will be able to hold 5 terra bytes of data. This technology is not likely to be introduced for another 10 years." (Watson, pg. 1)

### Sources

The following sources were consulted in compiling this article:

- Compucon, DVD Technology

- Poor, Alfred, 21st Century Storage, PC Magazine

- Rex, William, VCR Killers: So Long VHS, DVD Players are Here, PC Computing, April '97

- Watson, Richard, Data Management, an Organizational Perspective.

### A note from Sam

I'm not so sure about the end of CD-ROM. Remember those large cassettes and those small Sony tapes that wouldn't play on "regular" micro tape players, the original reel-to-reel tape players, the original color TV disks, etc. etc. etc. So, he may be right! Where are those systems now? It will be interesting to watch and see. Keep reading **ES&T!**

### Something to think about

A force is often defined as being "a push or pull." My physicist professor at Akron University said that was nonsense. He, and many other enlightened scientists, claim there is no such thing as a pull. For example, when you "pull" a sled you are actually pushing the ground with your feet.

I cannot defend the position that everything is a push. However, I can't even defend against the idea that the earth is flat. So, I'll go with the idea that a force is a push or pull.

What do you think? ■

## Coming next month in **ELECTRONIC**

Servicing & Technology

The December issue promises to be chock full of useful information for consumer electronics technicians. Our article on troubleshooting techniques will be a feature by Homer Davidson describing how to locate the cause of the problem when a TV screen is too dim, too bright, or there's no light on the screen at all.

If you're having a problem finding parts to complete a repair, and who isn't, another article in December: "Replacement parts/servicing information," will provide an abundance of tips on how to find the supplier of that elusive resistor, capacitor, transistor, diode or integrated circuit. Moreover, we'll supply you with an updated list of manufacturers and other suppliers who might just have that hard to find part on their shelves.

And if you've ever found those mechanical subsystems in VCRs, CD players, audio tape players, and the like more trouble than they should be, an article entitled "Mechanical subsystems servicing," will shed some light on how to go about troubleshooting and correcting those mechanical problems.

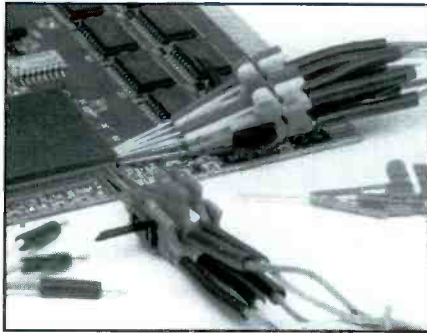

**Test clips**

Emulation Solutions announces a new micro test clip that works on small pitch IC leads. The clips are capable of connecting to devices such as plastic quad flat packs (PQFPs), small outline packages (SOPs) and thin small outline packages (TSOPs) with lead pitch of down to 0.20mm. The clips also support side-by-side connections and have a holding rod to manage multiple connections.

Circle (90) on Reply Card



**Two new troubleshooting tools**

Huntron Instruments announces the addition of two new models to its product line. The Huntron Tracker 2500 and Huntron Tracker 4000 include new voltage, frequency, and resistance test parameters. Many of today's portable electronic devices, from laptop PCs and PDAs to cellular phones, are designed with 3V or lower logic circuits. The test ranges on these testers suit them for troubleshooting these types of products. The actual values of test signals can be viewed on the instrument's front panel, helping the user to record the optimum range to provide the best analog signature. Up to 100 ranges are available on the model 2500, and the model 4000 can supply as many as 600 different ranges.

Circle (91) on Reply Card

**Portable mini-torch**

Wahl Electronics introduces the EZ-Torch, a portable mini-torch. Powered by



a replaceable butane cartridge that is readily available, the unit has an adjustable flame and operates at temperatures up to 237°F to perform a variety of tasks. The torch provides approximately 20 minutes of use per cartridge. It is useful for such tasks as soldering and brazing.

Circle (92) on Reply Card

**Heavy-duty DMMs**

Wavetek introduces the HD110B and HD115B, a new generation of heavy-duty (HD) multimeters. These new meters are designed to withstand continuous and long-lasting use in the most demanding field environments, says the manufacturer. They are resistant to damage from water, dust, chemicals, dropping and voltage transients, and spikes. The new HDs feature oversized character display and a new patented ergonomic shape. They are useful for electricians, electrical contractors, industrial plant personnel, and HVAC/R installers and servicers.



Functions include 1500Vdc/1000Vac voltage range, current to 10A, resistance to 20MΩ, continuity, diode test, and data hold. The model HD115B adds capacitance measuring, and features maximum reading hold, ac peak hold, and backlight.

Circle (93) on Reply Card



**Capacitance meter**

B&K Precision introduces the Model 890 Capacitance Meter, featuring a large LCD with dual display, 5,000 counts resolution, and 10 automatically selected ranges with full scale value from 0.1 pF to 50 μF. Designed to meet the latest international safety standards, the meter's dedicated chip and microprocessor allow programmable high/low limits or pre-programmed standard capacitor tolerances, making it useful for measuring values, inspection, sorting capacitors, and testing against standard tolerances.

Circle (94) on Reply Card

**High performance current probe**

LeCroy Corporation is introducing the model APO15, a high-performance current probe for oscilloscopes that provides users with the ability to accurately measure signal current in a wide range of circuits. The probe features dc to 50MHz bandwidth, +/-30A maximum dc current measurement capability, 50A peak pulse current measurements, and 2% accuracy.

The probe has the ability to maintain a reading of 50A for current pulses up to 10 seconds. The device also reports to the user if the probe head is not closed properly or if the head is starting to overheat (due to high frequency, high current conditions). An added benefit is that all these error reports are shown as messages on the DSO display.

Circle (95) on Reply Card

# Test Your Electronics Knowledge

## Answers to test (from page 23)

1. The answer is NO. Beginning students are sometimes fooled into trying to solve the problem by arranging the resistors into series and parallel combinations. I'll solve the problem in the next issue of *ES&T* (in "WDYKAE?").

2. In this type of problem you need to divide MHz by kHz  
 $?kHz = 25 \times 10^6 / 10^3 = 25 \times 10^3$

3. Yes. The resonant frequency occurs when the admittances of the two branches are equal. Adjusting the resistance of  $R_2$  changes the admittance of the L- $R_2$  branch.

4. 100000

5. You can't use Ohm's law in a circuit with a non-linear resistor. (Also, you can't get that many decimal places using an analog meter. Phone should have stayed home that day!)

6. 2256 (invert the fraction to 6/1 and multiply.)

7. Distilled water, which is an insulator, is used in the cooling system.

8. That is correct.

9. A — A 20-meter whip antenna won't go under the bridge.

10. NOPE! Not if you cut the line in

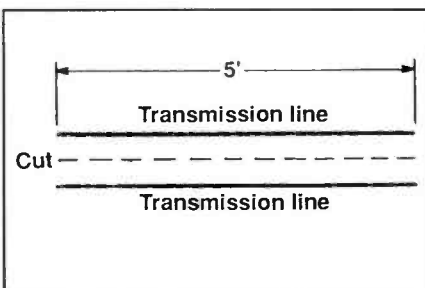

Figure 3. If you cut a 300 $\Omega$ , 5-ft. length of parallel-wire transmission line in half lengthwise, you will not have two 2.5 ft. lengths of 300 $\Omega$  transmission lines.

half lengthwise. See Figure 3. Sorry about that. The devil made me do it! (When a test question is improperly

worded, as number 10 is, you get full credit no matter what your answer (or no answer) is!

A Bell Atlantic Company  
**Howard W. Sams**

**Buy PHOTOFACT<sup>®</sup>**  
in brand-name specific sets!

**Introducing...**

**Branded PHOTOFACT Sets**

You can now buy PHOTOFACT<sup>®</sup> grouped by manufacturer brand name. Get an average of **25 PHOTOFACT<sup>®</sup> folders, covering over 50 models and spanning several years, all for just \$139.95 per set. Choose from RCA, Zenith, Sony, JVC, GE, and all major manufacturers, including off-shore brands.**

Visit your local distributor or call

**800-428-7267**

for details on Sams' new  
**Branded PHOTOFACT<sup>®</sup> Sets.**

Find out which manufacturers are covered, along with the years, models, and chassis included in each **Branded PHOTOFACT<sup>®</sup> Set.**

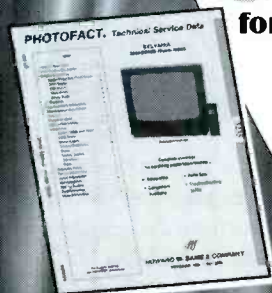

Circle (69) on Reply Card



## Electronic components and computer products catalog

Jameco Electronics has released a new catalog with thousands of ICs, components, tools, test equipment, and computer products for OEMs, engineers, educators, and service/repair technicians. The free 140-page catalog features 175 new products, including LEDs, serial LCD modules, solenoids, buzzers, batteries, power supplies, hobby kits, motherboards, digital cameras, graphics cards, printers, and more.

Circle (80) on Reply Card



## Data communications catalog

New cabling products, fiber optic and radio modems, PC communications cards, and test gear, as well as several new interface converters, have been added to the

B&B Electronics catalog. The new catalog shows a full line of data acquisition equipment and accessories, plus a wide range of interface converters and other serial, parallel and USB communications components.

Circle (81) on Reply Card

## Data logger catalog

Onset's new catalog provides details on a wide range of small, inexpensive, battery-powered data loggers used to record temperature, humidity, ac current, light intensity, 4mA to 20mA, voltage, rainfall, events, motor on/off, light on/off, and open/closed. The catalog includes 17 new products such as the splash-proof HOB0 Pro for monitoring temperature and relative humidity in industrial environments and the unique HOB0 Shuttle to retrieve data from loggers where they are deployed. Also included are new 4-channel loggers with a range of plug-in sensors for temperature, ac current, and 4mA to 20mA.

The 16-page catalog includes color photographs, detailed specifications, and pricing for all of the 34 products described. A comprehensive selection guide makes it easy to find data loggers for specific applications.

Circle (82) on Reply Card

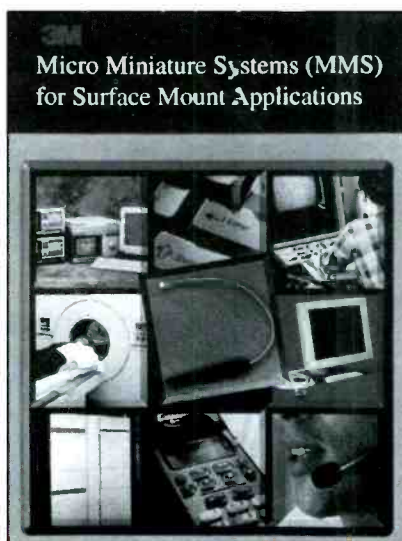

## Electronic interconnect assemblies for surface mount applications

A new brochure describing electronic interconnect assemblies for wireless and high performance computing is now available from the 3M Electronics Products Division. The brochure is titled

Micro Miniature Systems (MMS) for Surface Mount Applications.

The 8-page color brochure has information on low cost solutions to maximize the quality of signal transmission in RF interconnections. It features connector and cable specifications, solder procedures, drawings, ordering information, and full color photos.

For those who require them, the latest technical service drawings can be downloaded from the 3M interconnects Website at: <http://www.3M.com/interconnects>.

Circle (83) on Reply Card

## Test system and VXI products catalog

Hewlett-Packard announces its 1998 Test System and VXI Products Catalog, which contains a complete selection of test-system components, VXI products and services that help reduce the cost of building test systems. The catalog provides test engineers with information on fast, easy, and cost-effective ways to design, configure and install test systems to meet a wide range of application.

The full-color 176-page catalog, designed to make finding test products quick and easy, contains product descriptions and summary specifications, and an expanded portfolio of products including mainframes, VXI modules, M-modules, and a high speed interface.

A new, CD-ROM version of the catalog, called the HP system builder's source CD, gives users quick access to expanded product information. It also provides powerful VXI system-configuration software, printable technical data sheets, tutorials, HP VEE, and HP BASIC evaluation software, as well as catalogs for HP channel partners and HP power products.

Circle (84) on Reply Card

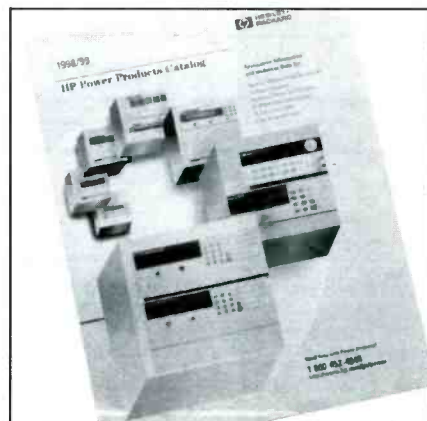

# ES&T BOOK SHOP



**ES&T Presents Computer Troubleshooting & Repair**  
Features information on repairing Macintosh computers, a CD-ROM primer, and a color monitor. Also included are hard drive repair tips and computer diagnostic software.  
61087 .....\$24.95

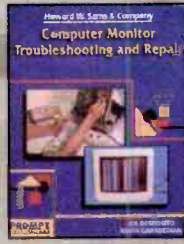

**Computer Monitor Troubleshooting & Repair**  
Learn the basics of computer monitors with chapters on tools and test equipment, monitor types, special procedures, how to find a problem, and how to repair faults in the CRT.  
61100 .....\$34.95



**1998 Computer Monitor Tips**  
Includes over 2,000 troubleshooting and repair tips listed by manufacturer name and model number featuring such major names as Apple, Gateway, Compaq, IBM, and Dell.  
61160 .....\$49.95



**ES&T Presents the Test Equipment Guide**  
Includes the latest information on how to choose the best equipment, how to build test equipment and accessories, how to set up the ideal service bench, and how to put together a practical tool kit.  
61089 .....\$24.95

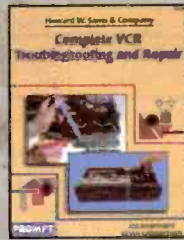

**Complete VCR Troubleshooting & Repair**  
In addition to troubleshooting procedures, this book contains nine detailed VCR case studies, each focusing on a particular model of VCR with a very specific and common problem.  
61102 .....\$34.95



**Electronic Troubleshooting & Servicing Techniques**  
The premiere guide for hobbyists, technicians, and engineers to a variety of troubleshooting tests, measurement procedures, and servicing techniques.  
61107 .....\$29.95



**ES&T Presents TV Troubleshooting & Repair**  
Presents important and new information that will make it possible for technicians, students, and electronics hobbyists to service TVs faster, more efficiently, and more economically.  
61086 .....\$24.95

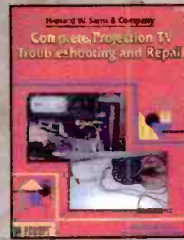

**Complete Projection TV Troubleshooting & Repair**  
Covers everything from the basics of projection circuits, tools and test equipment, TV types, safety procedures and measurements, to the finely detailed repair techniques.  
61134 .....\$34.95

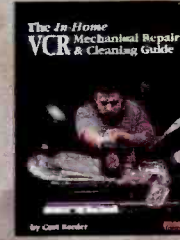

**In-Home VCR Mechanical Repair & Cleaning Guide**  
Regular VCR maintenance is critical to prolonging the life of your equipment, and this book shows readers the tricks and secrets of the trade using just a few small hand tools.  
61076 .....\$24.95



**Troubleshooting & Repair Guide to TV, Second Edition**  
The most comprehensive, complete, and up-to-date television repair book available, with tips on how to troubleshoot the newest circuits in today's TVs.  
61146 .....\$34.95

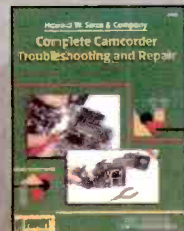

**Complete Camcorder Troubleshooting & Repair**  
Contains sound troubleshooting procedures beginning with the external parts of the camcorder, then narrowing the view to gears, springs, pulleys, lenses, and other mechanical parts.  
61105 .....\$34.95

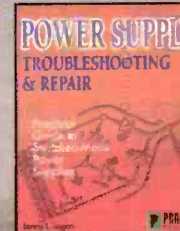

**Power Supply Troubleshooting & Repair**  
Designed to provide technicians with a better understanding of how switched-mode power supplies operate. It also provides practical, useful procedures to follow when troubleshooting power supplies.  
61138 .....\$24.95

**YES!** I want to learn from the experts. Rush me my book(s) right away!

Please add \$4 shipping & handling. **FREE shipping & handling** for orders \$50 and over.  
Please make your check or money order payable to: Electronic Servicing & Technology  
U.S. and possessions - add \$4 shipping/handling. **FREE S/H** on orders \$50 and over. Foreign - shipping/handling charges are calculated by order weight & destination. A \$4 credit will be applied for Foreign orders over \$50.

**To Order Call  
516-681-2922**

Qty	Order#	Description	Price	Total Price
<b>Shipping/Handling</b>				
<i>New York Residents add applicable sales tax</i>			<b>Total</b>	

Name \_\_\_\_\_  
 Address \_\_\_\_\_  
 City \_\_\_\_\_ State \_\_\_\_\_ Zip \_\_\_\_\_  
 MC/VISA/AMEX/Discover # \_\_\_\_\_ Expires \_\_\_\_\_  
 Form of payment:  MC  VISA  AMEX  Discover  Check  Money Order

Please mail your orders to: **Electronic Servicing & Technology, 25 Newbridge Rd, Hicksville, NY 11801-9962 FAX- 516-681-2926**

# CLASSIFIED

Classified advertising is available by the word or per column inch.

**By-the word.** \$1.65 per word, per insertion, pre-paid Minimum charge is \$35 per insertion. Initials and abbreviations count as full words. Indicate free category heading (For Sale, Business Opportunities, Miscellaneous, Wanted). Blind ads (replies sent to ES&T for forwarding) are \$40 additional. No agency discounts are allowed for classified advertising by the word. Contact Alycia NicholSEN at 516-681-2922 to place your classified ad (by-the-word). Mastercard, VISA, American Express and Discover are accepted for FAX or mail orders.

**Per column Inch** (classified Display): \$235 per column inch, per insertion, with frequency discounts available, 1" minimum, billed at 1/4" increments after that 10" maximum per ad. Blind ads are \$40 addition. Reader Service Number \$25 additional to cover processing and handling costs. (Free to 4-inch or larger ads.) For more information regarding classified display advertising please call 516-681-2922. Optional color (determined by magazine) \$150 additional per insertion.

Send your order, materials and payments to:

**Electronic Servicing & Technology, 25 Newbridge Road, Hicksville, NY 11801**  
**Attn: Classified Department Ph: 516-681-2922 FAX: 516-681-2926**

## FOR SALE

**STEPS TO TROUBLESHOOTING ELECTRONIC PROBLEMS IN CIRCUITS.** \$25.00. Steps to setting up your own TV repair store. Mail \$100.00 certified check or money order to: Arnold Burns, 425 East 51st Street, Brooklyn, NY 11203.

( ( **36,000 REPAIR TECH-TIPS** ) ) **STEP-UP OPPORTUNITY.** You may purchase our Windows 95/98 CD data-base only, 1987 thru Nov 98 for **\$99.00** or Paper Format in (5) manuals for **\$150.00**. If you are satisfied with our product, you may have your purchase applied to our full membership of **\$350.00** with Telephone Tech Support — FCCID Cross-Reference Manual — Tip informer magazine, 6-month updates of 2,000 repairs at reduced cost. **"GET TO THE BOTTOM LINE PROFITABLY."** CALL TODAY and speak to service center owner and technician **ED Erickson, NESDA MEMBER** and past president of the (Professional Electronics Assn. of South Florida) **800-474-3855** or 954-349-2455.

**SENCORE, TEKTRONIX, HEWLETT PACKARD** (all models). We **BUY, SELL, & TRADE**. Please call **"CHOICE ELECTRONICS"** for all of your test equipment needs. Complete financing options available. Call 1-800-609-0677, 605-361-6386 ask for Lance Tople.

**FURTHER PRICE REDUCTION.** Diehl Mark III \$49, Diehl Mark V Horizontal circuit tester \$169. New. Conductive coating for remote control keypads \$9.99 ppd. **WEEC**, 2411 Nob Hill Road, Madison, WI 53713. 608-238-4629, 608-273-8585.

**TV CASE HISTORIES:** Volume 7 with 3,045+ histories. Satisfaction assured. Only \$59 (plus \$3.25 shipping). Over 8,100 books and supplements sold with only 1 returned for a refund! **Mike's Repair Service**, P.O. Box 217, Aberdeen Proving Ground, MD 21005. Same mailing address 34+ years. Send SASE for samples. 410-272-4984, 1-800-2-FIX TVS 11am-9pm. ( <http://www.netgsi.com/~mikesrs>).

**Factory service data, used-Sams, books, vintage parts. AG Tannenbaum**, Box 386, Ambler, PA 19002. 215-540-8055, fax 215-540-8327, **On-line catalog: [www.agtannenbaum.com](http://www.agtannenbaum.com)**.

**TEST EQUIPMENT BOUGHT & SOLD: OSCILLOSCOPES, ETC.** 925-706-0177. FAX: 925-706-0156.

**IN-CIRCUIT CAPACITOR ESR TESTER** — Find bad caps FAST and RELIABLY with the new Capacitor Wizard in-circuit ESR Tester! Great for monitors, switching power supplies, TVs, etc. Only \$179.95. MC/VISA. **Independence Electronics Inc.**, 800-833-1094, [www.awiz.com](http://www.awiz.com).

## FOR SALE

**HORIZONTAL OUTPUT STAGE ANALYZER-** Test and isolate problems in the H.O.S.A. and its interdependency loop in 10 minutes or less. Must see demo training video available, a great troubleshooting aide that's very educational which is created by an EE engineer with over 30 years of experience. H.O.S.A. is \$175.00 (satisfaction guaranteed) and the video is \$10.00. No need to spend thousands on other analyzers. Prices include S & H or for free information, send to: Luz Research Corp. P.O. Box 350875, Miami, FL 33135, 305-642-6438.

**SERVICE TIPS for FREE!!!** \*\*\*\*\* That's right it's **FREE!!** **PROFESSIONAL BOARD LEVEL & COMPONENT LEVEL REPAIRS** for TV's, VCR's, Projection TV's, CAMCORDER's, CD Players, Audio and other repairs on computer disk. **ADD** your own repair tips. **PRINT** out repair tips. **BACKUP** & save **Your** repairs. Want to share your own repair tips? If you do, we will send you **FREE** Updates!!! Ask about our **TIP EXCHANGE** policy. For IBM compatible computers with a hard drive and some Apple Macs. **Get your FREE Stage 1 SERVICE TIPS PROGRAM Now!!!** \*\*\*\*\* **FREE CALL — CALL NOW!!! CALL 1-800-215-5081. \*\*\*\*\***

**SERVICE TIPS \*\*\*\*45,000 technical SERVICE TIPS. SERVICE TIPS THE ONLY NESDA APPROVED TECHNICAL TIPS PROGRAM available for WINDOWS/DOS at \$199.95 (plus s&h). SEE OUR DISPLAY AD ON PAGE 2.**

**TEST EQUIPMENT FOR SALE: REASONABLE PRICES SENCORE, TEKTRONIX, HP and MUCH MORE.** View complete list at: <http://www.astglobal.com> or contact: **AST GLOBAL ELECTRONICS.** Voice: 888-216-7159; Fax 814-398-1176; e-mail: [ales@astglobal.com](mailto:ales@astglobal.com)

**NAP Tuner 340309.** RCA Tuner TCHRIA or TCCRIA and more. Snowy picture? Will rebuild for \$25.00, Free Shipping. **Tip Top TV & VCR**, 18441 Sherman Way, Reseda, CA 91335, 818-345-1974.

**WinSTIPS!** — over **72,000** current Service tips from **KD T-V, NESDA**, & over 600 contributors! 380 brands (TV, VCR, Computer Monitor, Microwave, Camcorder, Audio, Misc.) Add your tips. Alphabetized symptoms. Tip exchange. Print tips. Symptom/Info/Cure Search. VCR cross. Sams similar-model cross. Finest ORIGINAL data. One-button update from web. Advanced Multiple Search, One-button e-mail in your tips! Windows 95/98/NT **\$149.95.** Dos **\$89.95.** Demo full registerable from <http://www.kdtviwe.com> updated monthly. **KD T-V 514 3rd St. Aurora, IN 47001. TOLL FREE 1-888-KD-STIPS.** All c/cards. Ken Hull C.E.T.



# CLASSIFIED

## WANTED

**WANTED:USED TEST EQUIPMENT. TURN IDLE OR EXCESS EQUIPMENT INTO CASH. AST GLOBAL ELECTRONICS.** Voice: 888-216-7159; Fax 814-398-1176; e-mail: sales@astglobal.com.

## BUSINESS OPPORTUNITIES

**CONSUMER ELECTRONICS SERVICE BUSINESS/BUILDING.** Centrally located in Connecticut, well established. Authorized for major brands. Some financing available. 860-828-6448.

## BUSINESS OPPORTUNITIES

**SERVICE CENTER FOR SALE:** Great opportunity in the corner of Tri-state area. Offers outstanding growth potential for the right person. High growth area, low rent. High traffic volume, audio-video-cam-corder-office products repairs. Proven business, yearly revenue increases. Phone: 864-882-6580. Ask for Ian.

**CENTRAL FLORIDA TV/ELECTRONICS Business/Building.** Heart of the retirement area. 36 years (75K). Owner retiring. 941-385-0359.

**NORTHWEST MONTANA CONSUMER ELECTRONICS/MOBILE RADIO BUSINESS.** Shop plus house. Good one man operation. 13 years (150K). Owner retiring. 406-675-0618.

# READERS' EXCHANGE

Readers' Exchange is a free service.

The following restrictions apply to Readers' Exchange:

- Only individual readers may use Readers' Exchange, and items must be restricted to those that are ordinarily associated with consumer electronics as a business or hobby. If you're in business to sell the item(s) you want to offer for sale, the appropriate place for your message is in a paid advertisement, not Readers' Exchange.
- Readers' Exchange items must be restricted to no more than three items each for wanted and for sale.
- All submissions must be typed or printed clearly!

**Send your Readers' Exchange submissions to:**

**Readers' Exchange, Electronic Servicing & Technology, 25 Newbridge Road, Hicksville, NY 11801**

## FOR SALE

Sencore VA62 with VC63 and NT64 NTSC, \$1500.00. Also SC61, mint condition, still in box, \$1500.00. Contact: Darlene, 281-424-2744 after 6 p.m. Central.

Sencore VG91/TVA 92 pair with 50KV probe, \$2,000.00. VG93 VCR analyzer, \$1,700.00. LC102/SCR250, \$1,400.00. B&K 2125A scope, \$400.00. Some TV/VCR repair tools and manuals as well. Sell all for \$5000.00. Contact: Pete Needham, 250-865-2423 or e-mail: pene@titan-link.com.

Heathkit oscilloscope Model 0-12; 5MHz single trace with probe and manual, \$25.00. Heathkit and Pace capacitor checkers, both \$35.00. Heathkit digital multimeter, Model IM-2215 with manual, \$40.00. Sam Photofact sets 1095 to 1366, all for \$75.00. GE 517, 518, 519, 520 H.V. triplers, \$10.00 each. Shipping not included. Contact: John Brouzakis, 237 Valley Circle, Charleroi, PA 15022, 724-483-3072.

Sencore LC102 Auto-Z with service manuals and leads, \$1000.00 C.O.D. Contact: Ken Schultz, 517-893-1354, (fax) 517-893-0283.

Sencore CM2000 computer monitor analyzer, \$1700.00 and Sencore VC93 VCR analyzer, \$1300.00. Both with all probes and manuals in excellent condition. Contact: Victor Burk at Burk's TV Service, 423-257-5501.

Sencore VA62 w/VC63 plus HP200, \$900.00. All probes, manuals and schematics. Excellent condition in original boxes. Contact: Frank, 727-392-0230.

Sencore LC102 capacitor and inductance checker with test leads and instruction manual. Contact: Ken, 517-893-1354.

Sylvania color test jig with adapters, \$65.00. Signal source video generator model 1219, \$250.00. Fluke diff volt meter 895A, \$75.00. Biotech electrosurgical analyzer, \$100.00. Tentelometer (never used), \$250.00. Tenma video head tester, \$45.00. VCR belts, drives and misc. parts, \$60.00. Manuals with most items. Contact: Ed, 603-669-1533 after 7 p.m., e-mail Edleduc@prodigy.net.

Sencore CM200 monitor analyzer, new condition, \$1250.00. Toshiba 15 Mhz dual channel scope, \$120.00. B&K frequency counter Model 1851, \$95.00. Contact: Jim, 313-526-5616 after 6 p.m.

## WANTED

Panasonic's I.C. chips AN7210 and AN7211 or SK and/or ECG/NTE exact pin for pin replacement. Contact: Dan Gherghe, P.O. Box 371, Steger, IL 60475-0371.

Zenith Z-449 computer video card. Need switch and jumper info. Contact: Robert Miller, Rt. 1, Box 223, Anadarko, OK 73005, 405-247-6553.

Western Electric, Fairchild, Pultec, UREI, Universal Audio, Cinema Engineering, Gates, Collins, Marantz, McIntosh, Tek 570 tracer, etc. tube sound equipment. Technics SP-10MK3 or 2A, EPA or SME tonearms, Nakamichi TA-4A receiver, CR-7 cassette turntables. Contact: 612-869-4963.

Curtis-Mathes VCR Model No. BV-730 service manual. Contact: Elmer Wieland, 237 Talbot Drive, Bedford, OH 44146, 440-232-8653.

Mitsubishi sound PC Board Number (1984)920B88301-KAgol94V-0, A240a19101, CS2184R, in excellent condition, reasonable price. Contact: Dennis, 854-A Louise Circle, Durham, NC 27705, 919-383-9659.

NEC projection TV Model PJ-4170EN, Ch. 10423. Need schematic and flyback transformer. Will pay for copy or copy and return. Contact: Bob Campbell, 303-617-1098.

ITT Schaub-Lorenz service information for stereo 5501 hi-fi radio/cassette. Contact: John Phipps, 1412 Navaho Trl, St. Charles, MO 63304-7325

Panasonic Model RT909 reel-to-reel. Need IC AN6251. Contact: Paul or Rose, 941-625-9888.

Loran "C" Ray NAV570. Would like to obtain service literature. Contact: Ken, Sea & Shore, 517-893-1354, 517-893-0283(fax).

**TUBES • TUBES • TUBES**  
**World's Largest Range**  
 Over 2,000 Types, Domestic & Foreign  
 **UP TO 85% OFF** Ask for price list  
  
**International Components Corporation**  
 Toll Free 800-645-9154 • N.Y. State 516-293-1500  
 107 Maxess Road, Melville, New York 11747

Circle (67) on Reply Card

**Do You Repair Electronics?**

Repair Databases for TV, VCR, Monitor, UL Audio, FCC, and more.

- Over 76,000 records
- Private user forums
- Live on-line chat rooms

**RepairWorld.com**

Electronic Corp 1 Herald Sq. Fairborn, OH 45324 (937) 878-9478

Circle (65) on Reply Card

**ULTIMATE HOME SHOP**

Complete tools for metal & woodworking



Starting at \$995  
 Easy to use Versatile Affordable  
**FREE CATALOG**  
 Call today!

Call 1-800-345-6342 or write: Smithy Dept. EST, PO Box 1517 Ann Arbor, MI 48106-1517

Circle (73) on Reply Card

The nation's one stop from **a to z**



**aiwa DENON PANASONIC FISHER PHILIPS RCA SANYO HITACHI SHARP JVC SONY MAGNAVOX ZENITH**

1-800-638-3328  
 1-800-888-FAXD

Circle (74) on Reply Card

**MOVING?**

If you're planning a move in the near future, don't risk missing an issue of Electronic Servicing & Technology. Please give us 6-8 weeks notice if you're planning on changing your address. Just write your new address and mail it, WITH YOUR SUBSCRIPTION MAILING LABEL, to:

**Electronic Servicing & Technology**  
 25 Newbridge Road, Hicksville, NY 11801

Get online with **ELECTRONIC** Servicing & Technology on Delphi!

**DELPHI INTERNET™**

To sign up dial **1-800-365-4636**

with your computer & modem, and enter **ELECTRONIC** at the signup password prompt! You can find Electronic Servicing & Technology in the Radio & Electronics Forum (GO RADIO).

Circle (1) on Reply Card

**ADVERTISERS' INDEX**

Company	Page Number	Reader Service Number	Advertiser Hotline
B & D Enterprises	23	61	888/815-0508
CES	IBC	98	888/CES-SHOW
Delphi Internet	64	1	800/365-4636
EIA Electronic Industries Alliance	5	2	703/907-7670
Electro Dynamics, Inc.	2,3	62,63	800/426-6423
Electronic Design Specialists	19	64	561/487-6103
Electronics Technicians Assoc.	49	77	765/653-4301
Electronix Corporation	64	65	937/878-1828
Herman Electronics	45		800/938-4376
International Components Corp.	64	67	800/645-9154
Isctet	45	75	817/921-9101
NCA/National Computer Assn.	45,49	76	800/615-6224
Parts Express	21	68	800/338-0531
Philips Service Solutions Group	IFC	120	800/851-8885
SBS Direct	45	70	800/603-9000
Sams & Company, Howard	59	69	800/428-7267
Sencore	7,13	71,72	800/SENCORE
Smithy Company	64	73	800/345-6342
Thomson Consumer Electronics	IBC	113	800/336-1900
Tritronics, Inc.	64	74	800/638-3328

We'd like to see your company listed here too. Call Evelyn Garrison at 425-557-9611 or Fax her at 425-557-9612 to work out an advertising program tailored to suit your needs.

**What's Your Best Servicing Value?**

The magazine that makes money for you - **ELECTRONIC** Servicing & Technology



Each month, **ES&T** brings you how-to service articles on TVs...VCRs... Computers... CD players... Microwaveovens... Audio products and more. It's the information you need to do your job everyday.

Regular columns and special features from experts will make you more efficient - and more profitable - in no time. Plus, our monthly PROFAX, a FREE 8-page pull-out of popular TV, VCR and computer schematics, makes **ES&T** an even greater value.

1-year, (12 issues) \$26.95  
 1-year Canada/Mexico \$36.95  
 1-year Foreign Air Post, \$44.95

2-years, (24 issues) \$49.95  
 2-years, Canada/Mexico \$69.95  
 2-years Foreign Air Post, \$85.95

**Electronic Servicing & Technology**  
 25 Newbridge Road, Hicksville, NY 11801 • Phone: 516-681-2922 • FAX: 516-681-2926

Desktop, notebooks, palmtop, mobile. And that's just the computers. Remote accessibility, portability, and innovation are what's important in information technology today. See it all at the Consumer Electronics Show, the world's largest and most comprehensive consumer technologies event.

Information technology is packing up its act and taking it on the road.

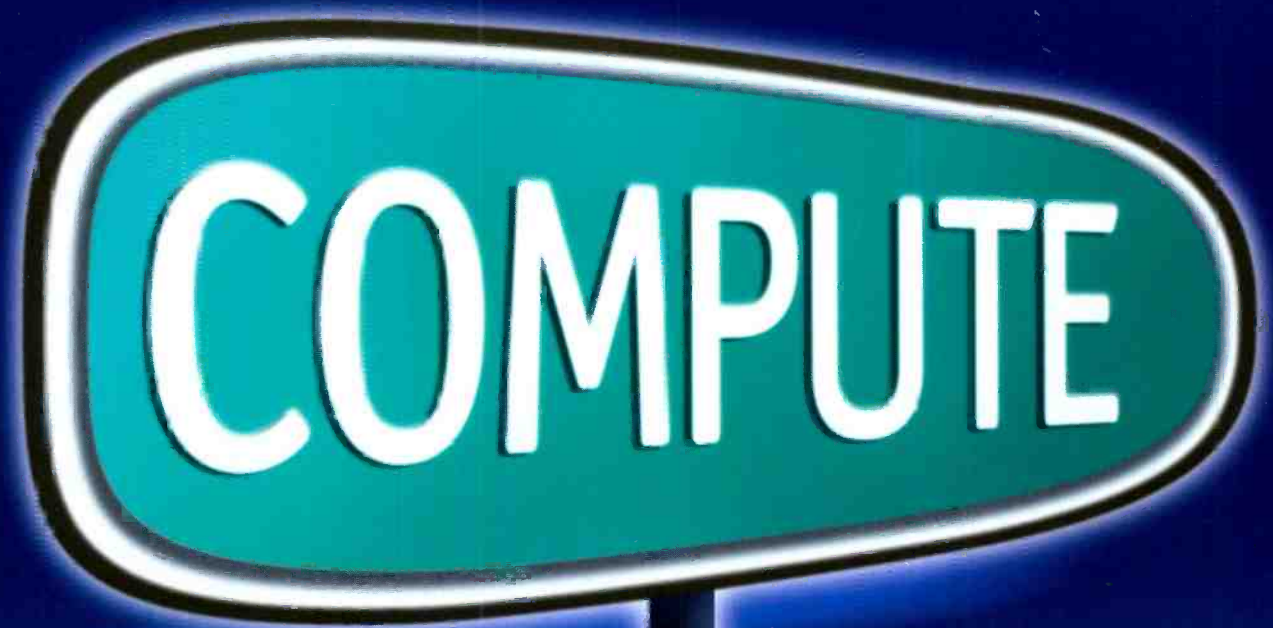

1999 International

**CES**

THE SOURCE FOR  
CONSUMER TECHNOLOGIES

Circle 9 on Reply Card

January 7-10, 1999, Las Vegas, Nevada  
Register online at [www.CESweb.org](http://www.CESweb.org), and save \$75.  
For fax or demand registration materials,  
call 1-888-CES-SHOW

Exact Semiconductors

# The Right Parts For The Job

“Trust Me!”

How many times have you heard that!

You built your reputation on hard  
work and quality repairs.  
Why change now?

Put your reputation on the line  
with two names you *can* trust.

SK *Series* and Thomson  
Consumer Electronics.

With over 1,700 exacts in  
stock, you won't have to look  
anywhere else. And when you're  
in need of any video heads,  
belts, tires, flyback transformers  
or video replacement parts,  
we have them too.

But we don't stop there.

Our continuing quality assurance and  
accuracy goes into every SK *Series* product.

For more information on SK *Series* products,  
contact your nearest Thomson Distributor.

SK *Series*...The parts you need to do the job. “Trust me!”

 THOMSON CONSUMER ELECTRONICS

**SK**

*Series*

Circle (113) on Reply Card